

Status of Neutrino Masses and Mixing

Carlo Giunti

INFN, Sezione di Torino, and
Dipartimento di Fisica Teorica, Università di Torino

giunti@to.infn.it

KIAS, Seoul, Korea, 14 October 2004

Introduction to Neutrino Mass, Mixing and Oscillations

Solar $\nu_e \rightarrow \nu_{\mu}, \nu_{\tau}$ + Atmospheric $\nu_{\mu} \rightarrow \nu_{\tau} \implies$ Three-Neutrino Mixing

Absolute Scale of Neutrino Masses

Cosmological Bound on Neutrino Masses

Neutrinoless Double- β Decay \iff Majorana Mass

Neutrino Mass

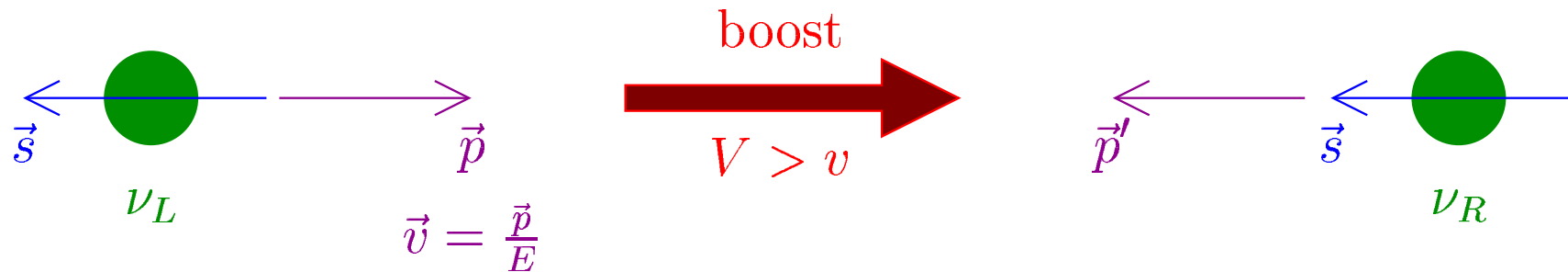

Standard Model: $\nu_L, \bar{\nu}_R \implies$ no Dirac mass term $\sim \nu_L \nu_R$
 (no $\nu_R, \bar{\nu}_L$)

Majorana neutrino: $\nu = \bar{\nu} \implies \bar{\nu}_R = \nu_R \implies$ Majorana mass term $\sim \nu_L \bar{\nu}_R$

Standard Model: Majorana mass term is not allowed by $SU(2)_L \times U(1)_Y$
 (no Higgs triplet)

Standard Model can be extended with ν_R ($e_L, e_R; u_L, u_R; d_L, d_R; \dots; \nu_{eR}, \nu_{\mu R}, \nu_{\tau R}$)

$\nu_L + \nu_R \implies$ Dirac neutrino mass term $\sim \nu_L \nu_R$ (as all other particles)

surprise: also Majorana neutrino mass for ν_R is allowed!

$$\text{Lagrangian neutrino mass term} \sim \begin{pmatrix} \nu_L & \bar{\nu}_L \end{pmatrix} \begin{pmatrix} 0 & m^D \\ m^D & m_R^M \end{pmatrix} \begin{pmatrix} \bar{\nu}_R \\ \nu_R \end{pmatrix}$$

$m^D \lesssim 100 \text{ GeV}$, but m_R^M can be arbitrarily large (not protected by any symmetry)

natural that $m_R^M \sim$ scale of new physics beyond the Standard Model $\implies m_R^M \gg m^D$

$$\text{diagonalization of } \begin{pmatrix} 0 & m^D \\ m^D & m_R^M \end{pmatrix} \implies m_1 \simeq \frac{(m^D)^2}{m_R^M}, \quad m_2 \simeq m_R^M$$

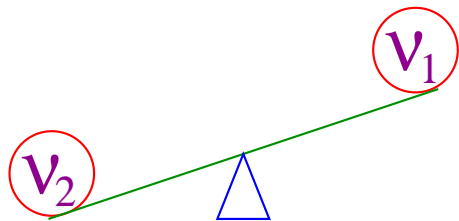

see-saw mechanism

natural explanation of
smallness of neutrino masses

massive neutrinos are Majorana!

Standard Model:

Lepton numbers are conserved

	L_e	L_μ	L_τ		L_e	L_μ	L_τ
(ν_e, e^-)	+1	0	0	$(\bar{\nu}_e, e^+)$	-1	0	0
(ν_μ, μ^-)	0	+1	0	$(\bar{\nu}_\mu, \mu^+)$	0	-1	0
(ν_τ, τ^-)	0	0	+1	$(\bar{\nu}_\tau, \tau^+)$	0	0	-1

$$L = L_e + L_\mu + L_\tau$$

Dirac mass term $\sim \nu_L \nu_R \implies \begin{pmatrix} \nu_{eL} & \nu_{\mu L} & \nu_{\tau L} \end{pmatrix} \begin{pmatrix} m_{ee} & m_{e\mu} & m_{e\tau} \\ m_{\mu e} & m_{\mu\mu} & m_{\mu\tau} \\ m_{\tau e} & m_{\tau\mu} & m_{\tau\tau} \end{pmatrix} \begin{pmatrix} \nu_{eR} \\ \nu_{\mu R} \\ \nu_{\tau R} \end{pmatrix}$

L_e, L_μ, L_τ are not conserved, but L is conserved $L(\nu_{\alpha R}) = L(\nu_{\beta L}) \implies |\Delta L| = 0$

Majorana mass term $\sim \nu_L \bar{\nu}_R \implies \begin{pmatrix} \nu_{eL} & \nu_{\mu L} & \nu_{\tau L} \end{pmatrix} \begin{pmatrix} m_{ee} & m_{e\mu} & m_{e\tau} \\ m_{\mu e} & m_{\mu\mu} & m_{\mu\tau} \\ m_{\tau e} & m_{\tau\mu} & m_{\tau\tau} \end{pmatrix} \begin{pmatrix} \bar{\nu}_{eR} \\ \bar{\nu}_{\mu R} \\ \bar{\nu}_{\tau R} \end{pmatrix}$

L, L_e, L_μ, L_τ are not conserved $L(\bar{\nu}_{\alpha R}) = -L(\nu_{\beta L}) \implies |\Delta L| = 2$

Neutrino Oscillations

[Pontecorvo, Sov. Phys. JETP 6 (1957) 429] [Pontecorvo, Sov. Phys. JETP 7 (1958) 172] [Gribov, Pontecorvo, Phys. Lett. B 28 (1969) 49]

[Eliezer, Swift, Nucl. Phys. B 105 (1976) 45] [Fritzsch, Minkowski, Phys. Lett. B 62 (1976) 72] [Bilenky, Pontecorvo, Sov. J. Nucl. Phys. 24 (1976) 316]

[Bilenky, Pontecorvo, Nuovo Cim. Lett. 17 (1976) 56] [Bilenky, Pontecorvo, Phys. Rept. 41 (1978) 225]

$$\alpha = e, \mu, \tau$$

$$|\nu_\alpha\rangle = \sum_k U_{\alpha k} |\nu_k\rangle$$

$$\nu_k \rightarrow m_k$$

Neutrino Mixing

$$|\nu_k(x, t)\rangle = e^{-iE_k t + ip_k x} |\nu_k\rangle \implies |\nu_\alpha(x, t)\rangle = \sum_k U_{\alpha k} e^{-iE_k t + ip_k x} |\nu_k\rangle$$

$$|\nu_\alpha(x, t)\rangle = \sum_{\beta=e,\mu,\tau} \underbrace{\left(\sum_k U_{\alpha k} e^{-iE_k t + ip_k x} U_{\beta k}^* \right)}_{\mathcal{A}_{\nu_\alpha \rightarrow \nu_\beta}(x, t)} |\nu_\beta\rangle$$

$$|\nu_k\rangle = \sum_{\beta=e,\mu,\tau} U_{\beta k}^* |\nu_\beta\rangle$$

Transition Probability

$$P_{\nu_\alpha \rightarrow \nu_\beta}(x, t) = |\langle \nu_\beta | \nu_\alpha(x, t) \rangle|^2 = |\mathcal{A}_{\nu_\alpha \rightarrow \nu_\beta}(x, t)|^2 = \left| \sum_k U_{\alpha k} e^{-iE_k t + ip_k x} U_{\beta k}^* \right|^2$$

ultrarelativistic neutrinos $\implies t \simeq x = L$ source-detector distance

$$E_k t - p_k x \simeq (E_k - p_k) L = \frac{E_k^2 - p_k^2}{E_k + p_k} L = \frac{m_k^2}{E_k + p_k} L \simeq \frac{m_k^2}{2E} L$$

$$P_{\nu_\alpha \rightarrow \nu_\beta}(L, E) = \left| \sum_k U_{\alpha k} e^{-im_k^2 L/2E} U_{\beta k}^* \right|^2$$

$$= \sum_k |U_{\alpha k}|^2 |U_{\beta k}|^2$$

\Leftarrow constant term

$$+ 2\text{Re} \sum_{k>j} U_{\alpha k} U_{\beta k}^* U_{\alpha j}^* U_{\beta j} \exp\left(-i \frac{\Delta m_{kj}^2 L}{2E}\right)$$

\Leftarrow oscillating term



coherence

$$\Delta m_{kj}^2 \equiv m_k^2 - m_j^2$$

[Nussinov, Phys. Lett. B 63 (1976) 201] [Kayser, Phys. Rev. D 24 (1981) 110], [Giunti, Kim, Lee, Phys. Rev. D 44 (1991) 3635]

[Kiers, Nussinov, Weiss, Phys. Rev. D 53 (1996) 53] [Giunti, Kim, Phys. Rev. D 58 (1998) 017301] [Giunti, Kim, Found. Phys. Lett. 14 (2001) 213],

[Beuthe, Phys. Rept. 375 (2003) 105], [Giunti, Found. Phys. Lett. 17 (2004) 103]

Two-Neutrino Mixing

$$k = 1, 2 \implies U = \begin{pmatrix} \cos \vartheta & \sin \vartheta \\ -\sin \vartheta & \cos \vartheta \end{pmatrix} \quad \Delta m^2 \equiv \Delta m_{21}^2 \equiv m_2^2 - m_1^2$$

$$\text{Transition Probability } (\alpha \neq \beta): \quad P_{\nu_\alpha \rightarrow \nu_\beta}(L, E) = \sin^2 2\vartheta \sin^2\left(\frac{\Delta m^2 L}{4E}\right)$$

$$\text{Survival Probability } (\alpha = \beta): \quad P_{\nu_\alpha \rightarrow \nu_\alpha}(L, E) = 1 - P_{\nu_\alpha \rightarrow \nu_\beta}(L, E)$$

$$\text{Averaged Transition Probability:} \quad \langle P_{\nu_\alpha \rightarrow \nu_\beta} \rangle = \frac{1}{2} \sin^2 2\vartheta$$

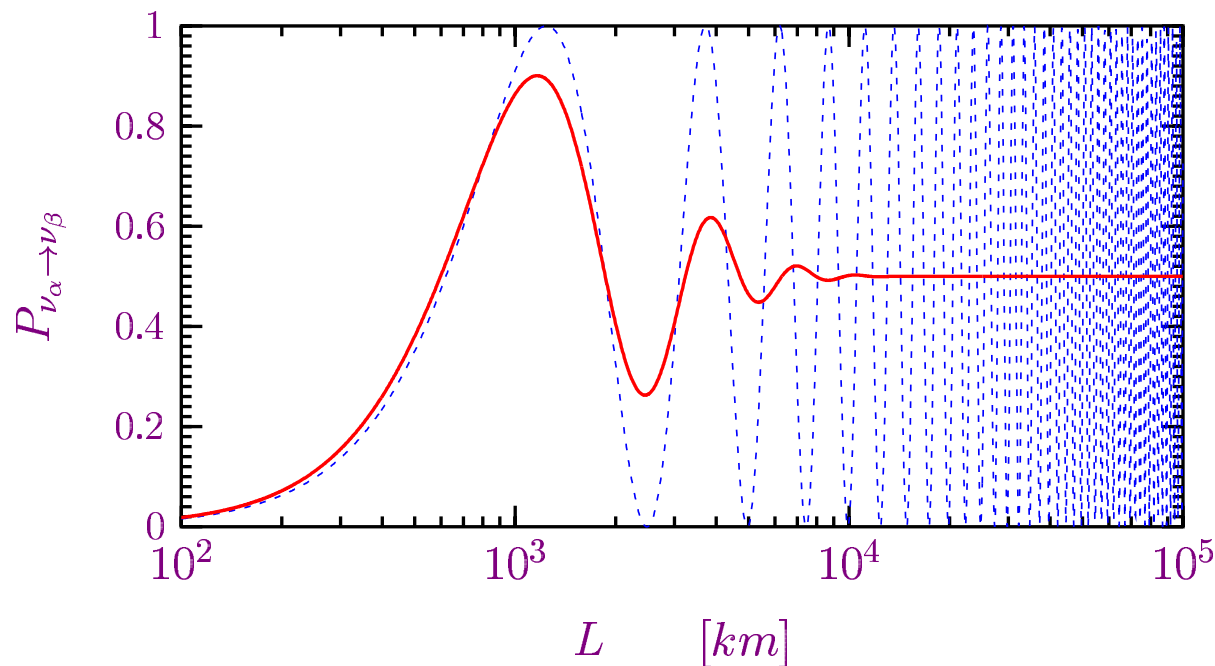

$$\Delta m^2 = 10^{-3} \text{ eV}$$

$$\sin^2 2\vartheta = 1$$

$$\langle E \rangle = 1 \text{ GeV}$$

$$\Delta E = 0.2 \text{ GeV}$$

Solar Neutrinos

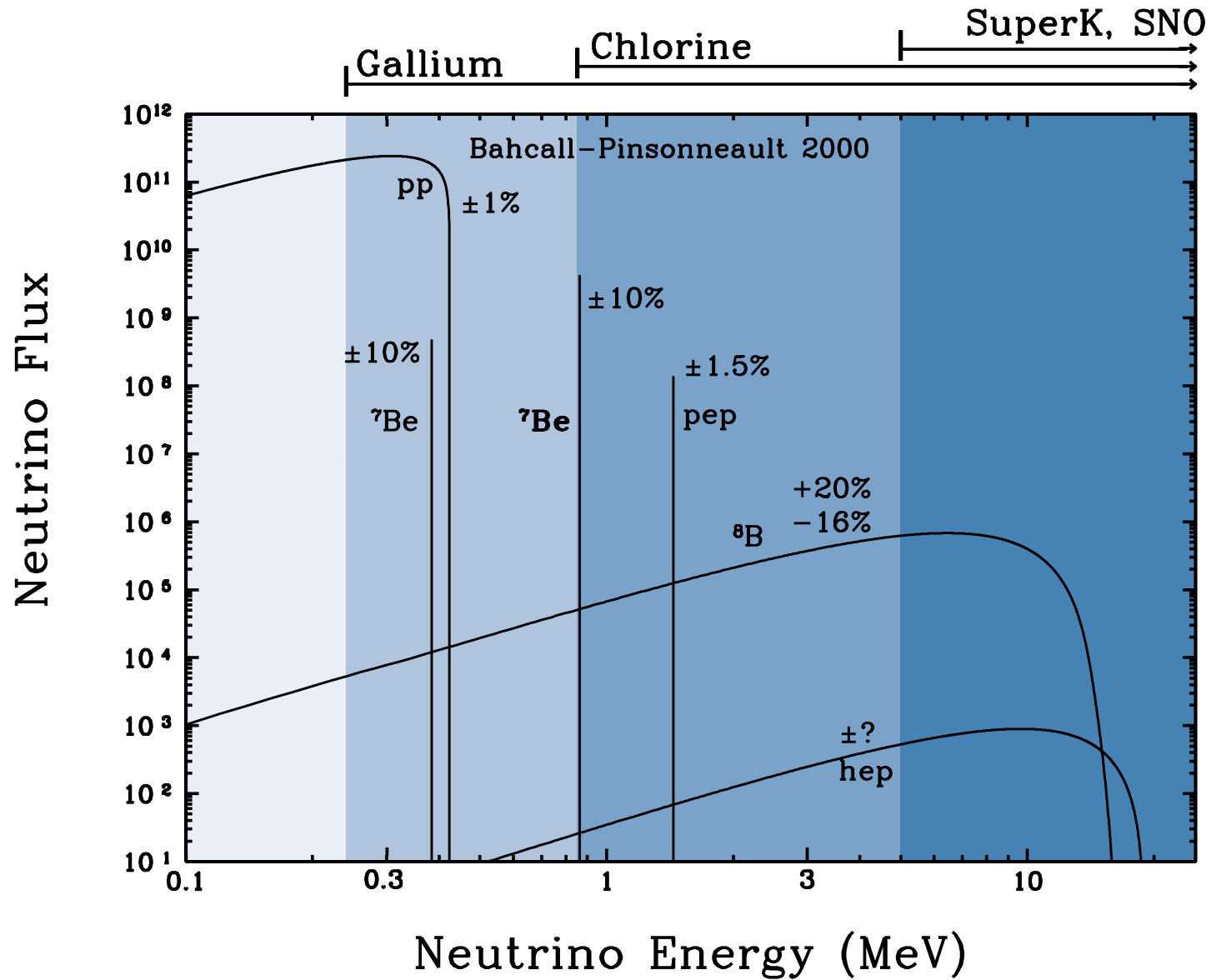

[J.N. Bahcall, <http://www.sns.ias.edu/~jnb>]

Main Characteristics of Solar ν Data

Experiment	Reaction	E_{th} (MeV)	ν Flux Sensitivity	Operating Time	$\frac{R^{\text{exp}}}{R^{\text{BP04}}}$
SAGE	$\nu_e + {}^{71}\text{Ga} \rightarrow {}^{71}\text{Ge} + e^-$ (CC)	0.233	$pp, {}^7\text{Be}, {}^8\text{B},$ $pep, hep,$ ${}^{13}\text{N}, {}^{15}\text{O}, {}^{17}\text{F}$	1990 – 2001	0.52 ± 0.04
GALLEX				1991 – 1997	0.59 ± 0.06
GNO				1998 – 2000	0.50 ± 0.08
Homestake	$\nu_e + {}^{37}\text{Cl} \rightarrow {}^{37}\text{Ar} + e^-$ (CC)	0.814	${}^7\text{Be}, {}^8\text{B},$ $pep, hep,$ ${}^{13}\text{N}, {}^{15}\text{O}, {}^{17}\text{F}$	1970 – 1994	0.30 ± 0.03
Kamiokande	$\nu + e^- \rightarrow \nu + e^-$ (ES)	6.75	${}^8\text{B}$	1987 – 1995 2079 days	0.49 ± 0.06
Super-Kam.		4.75		1996 – 2001 1496 days	0.406 ± 0.013
SNO D ₂ O phase	$\nu_e + d \rightarrow p + p + e^-$ (CC)	6.9		1999 – 2001 306.4 days	0.30 ± 0.02
	$\nu + d \rightarrow p + n + \nu$ (NC)	2.2			0.88 ± 0.11
	$\nu + e^- \rightarrow \nu + e^-$ (ES)	5.2			0.41 ± 0.05
SNO NaCl phase	$\nu_e + d \rightarrow p + p + e^-$ (CC)	6.9		2001 – 2002 254.2 days	0.27 ± 0.02
	$\nu + d \rightarrow p + n + \nu$ (NC)	2.2			0.90 ± 0.08
	$\nu + e^- \rightarrow \nu + e^-$ (ES)	5.2			0.38 ± 0.05

$$\Phi_{CC}^{SNO} = 1.76 \pm 0.11 \times 10^6 \text{ cm}^{-2} \text{ s}^{-1}$$

$$\Phi_{NC}^{SNO} = 5.09 \pm 0.64 \times 10^6 \text{ cm}^{-2} \text{ s}^{-1}$$



$$\Phi_{\nu_e}^{SNO} = 1.76 \pm 0.11 \times 10^6 \text{ cm}^{-2} \text{ s}^{-1}$$

$$\Phi_{\nu_{\mu}, \nu_{\tau}}^{SNO} = 5.41 \pm 0.66 \times 10^6 \text{ cm}^{-2} \text{ s}^{-1}$$

SNO SOLVED SOLAR NEUTRINO PROBLEM



NEUTRINO PHYSICS

(April 2002)

[SNO, Phys. Rev. Lett. 89 (2002) 011301, nucl-ex/0204008]

$\nu_e \rightarrow \nu_{\mu}, \nu_{\tau}$ oscillations



Large Mixing Angle solution

$$\Delta m^2 \simeq 5 \times 10^{-5} \text{ eV}^2 \quad \tan^2 \vartheta \simeq 0.4$$

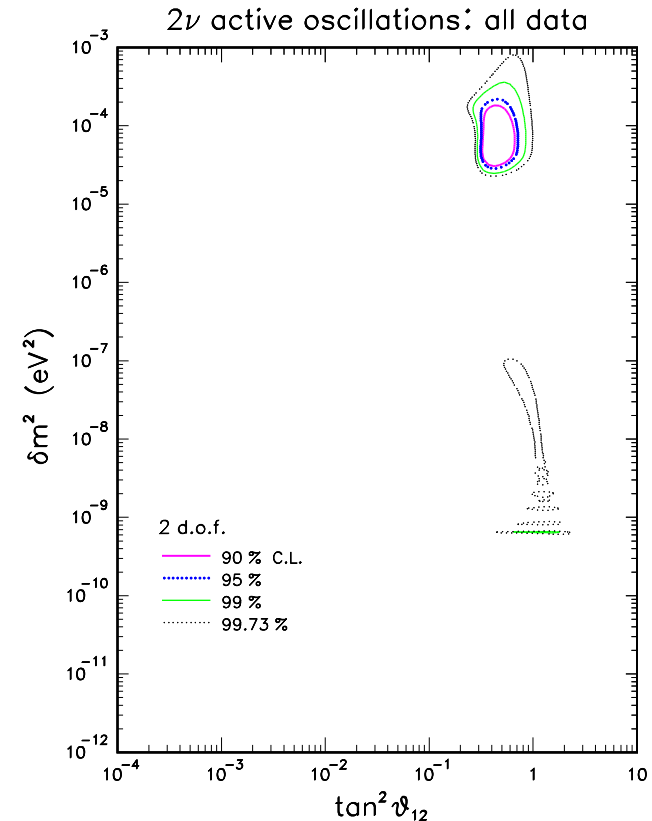

90%, 95%, 99%, 99.73% (3σ) C.L.

[Fogli, Lisi, Marrone, Montanino, Palazzo, PRD 66 (2002) 053010]

see also

[SNO, PRL 89 (2002) 011302]

[Barger, Marfatia, Whisnant, Wood, PLB 537 (2002) 179]

[Bahcall, Gonzalez-Garcia, Peña-Garay, JHEP 07 (2002) 054]

[SK, PLB 539 (2002) 179]

[de Holanda, Smirnov, PRD66 (2002) 113005]

[Aliani et al., PRD 67 (2003) 013006]

[Bandyopadhyay et al., PLB 540 (2002) 14]

[Creminelli, Signorelli, Strumia, hep-ph/0102234]

[Maltoni, Schwetz, Tortola, Valle, PRD 67 (2003) 013011]

KamLAND

spectacular confirmation of LMA (December 2002)

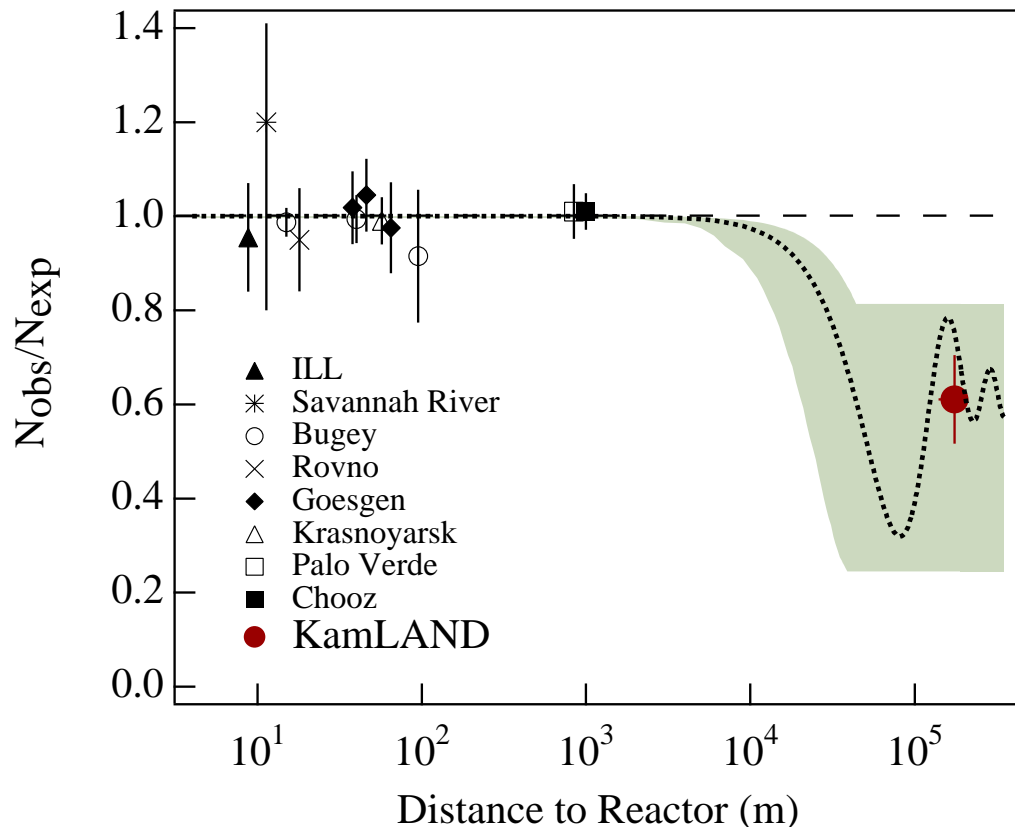

Shade: 95% C.L. LMA

$$\text{Curve: } \begin{cases} \Delta m^2 = 5.5 \times 10^{-5} \text{ eV}^2 \\ \sin^2 2\vartheta = 0.83 \end{cases}$$

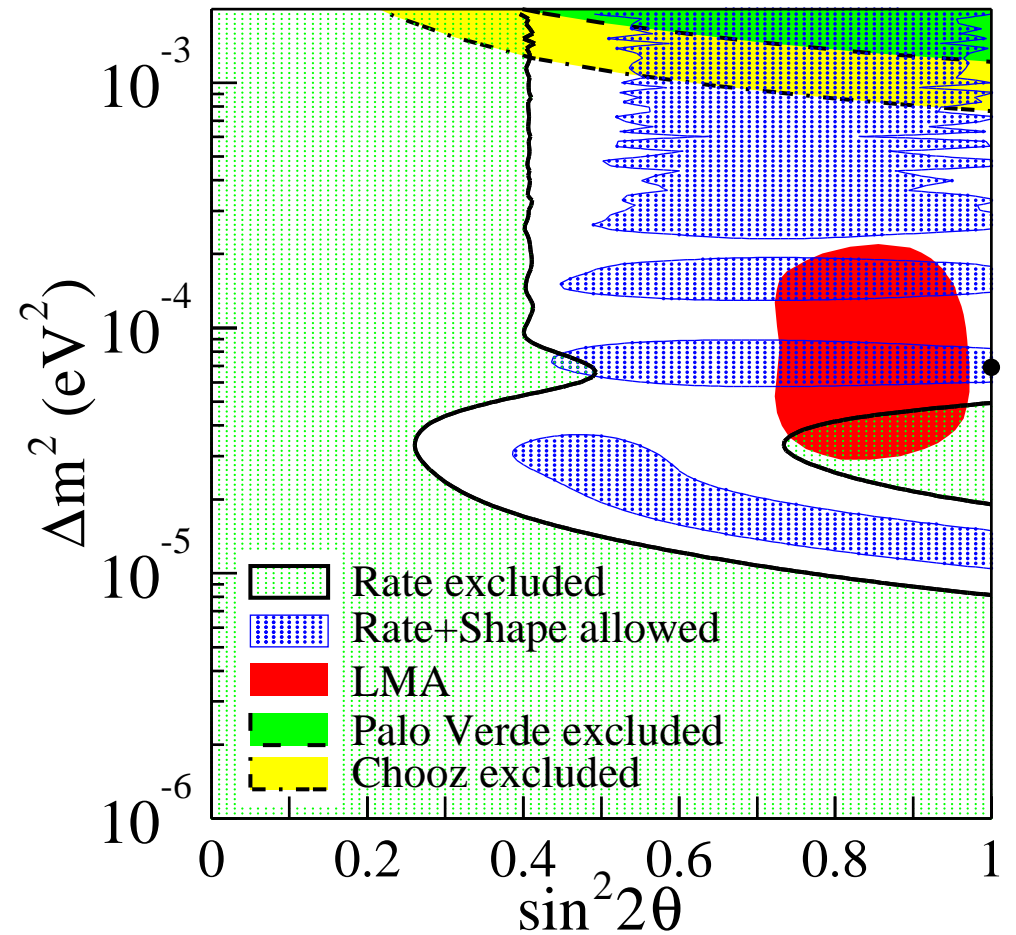

95% C.L.

[KamLAND, Phys. Rev. Lett. 90 (2003) 021802, hep-ex/0212021]

KamLAND: Evidence of Spectral Distortion

hep-ex/0406035, June 2004

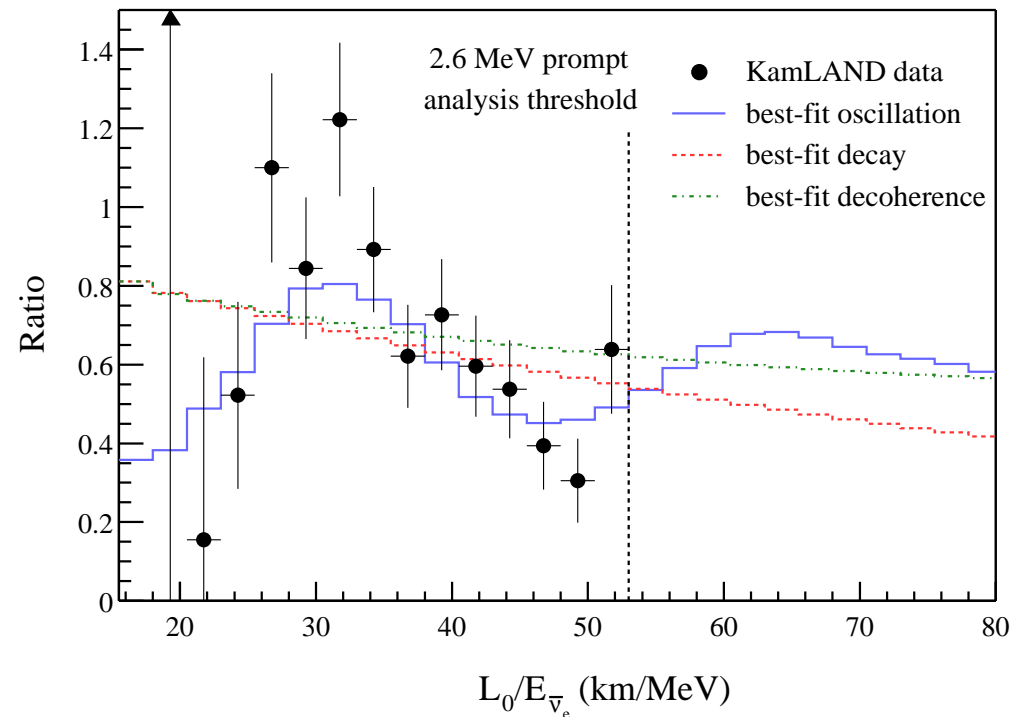
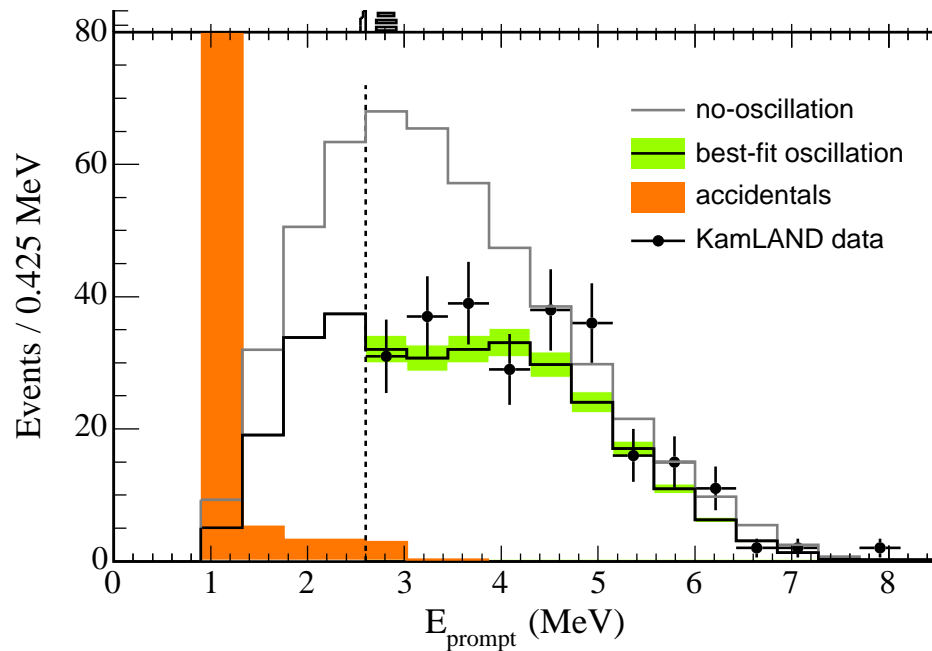

$$L_0 = 180 \text{ km}$$

The confidence level for reactor $\bar{\nu}_e$ disappearance is now 99.995%. The observed energy spectrum disagrees with the expected spectral shape in the absence of neutrino oscillation at the 99.9% confidence level but agrees with the distortion expected from $\bar{\nu}_e$ oscillation effects.

Combined Fit of Solar + Reactor Neutrino Data

[KamLAND, hep-ex/0406035]

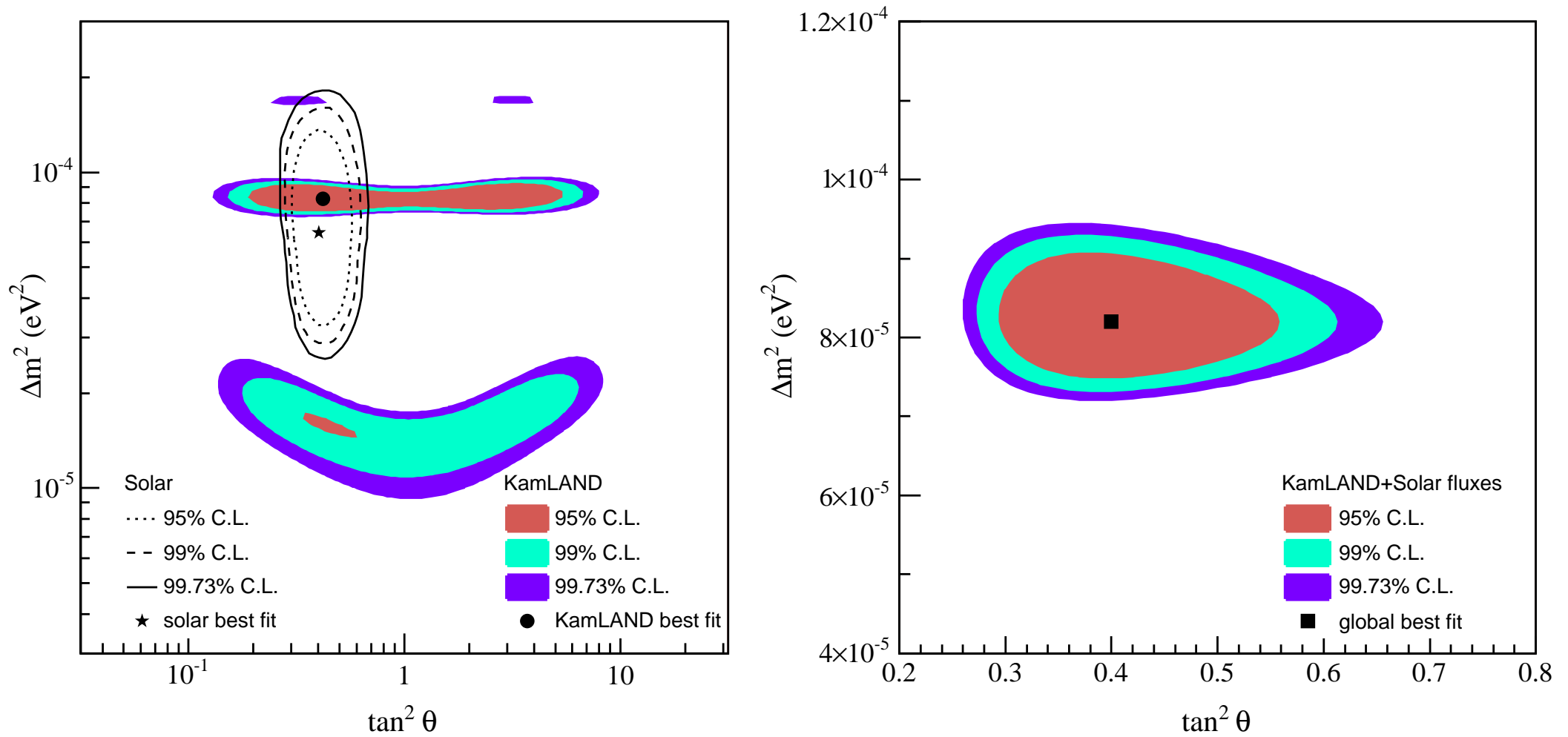

Best Fit: $\Delta m^2 = 0.82_{-0.5}^{+0.6} \times 10^{-5} \text{ eV}^2$ $\tan^2 \vartheta = 0.40_{-0.07}^{+0.09}$

Atmospheric Neutrinos

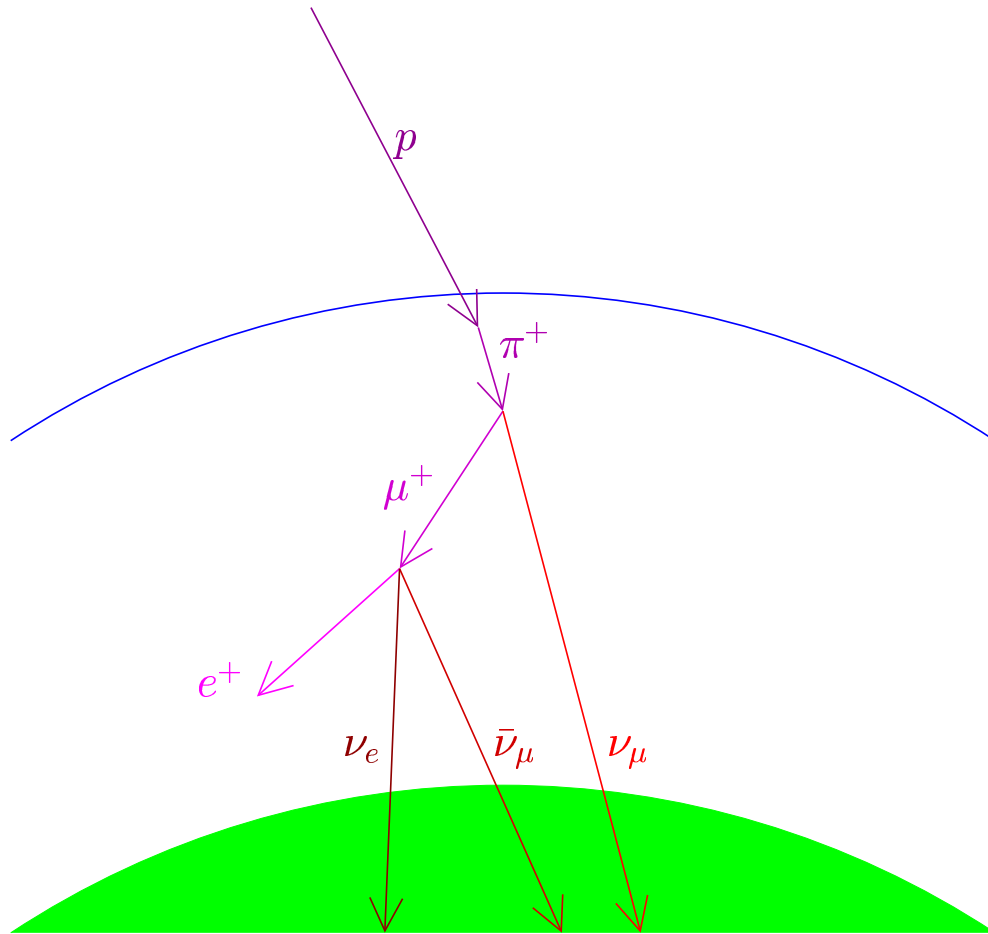

$$\frac{N(\nu_\mu + \bar{\nu}_\mu)}{N(\nu_e + \bar{\nu}_e)} \simeq 2 \quad \text{at } E \lesssim 1 \text{ GeV}$$

uncertainty on ratios: $\sim 5\%$

uncertainty on absolute fluxes: $\sim 30\%$

ratio of ratios

$$R \equiv \frac{\left[N(\nu_\mu + \bar{\nu}_\mu) / N(\nu_e + \bar{\nu}_e) \right]_{\text{data}}}{\left[N(\nu_\mu + \bar{\nu}_\mu) / N(\nu_e + \bar{\nu}_e) \right]_{\text{MC}}}$$

$$R_{\text{sub-GeV}}^{\text{K}} = 0.60 \pm 0.07 \pm 0.05$$

[Kamiokande, Phys. Lett. B 280 (1992) 146]

$$R_{\text{multi-GeV}}^{\text{K}} = 0.57 \pm 0.08 \pm 0.07$$

[Kamiokande, Phys. Lett. B 335 (1994) 237]

$$R_{\text{sub-GeV}}^{\text{SK}} = 0.61 \pm 0.03 \pm 0.05$$

[Super-Kamiokande, Phys. Lett. B 433 (1998) 9, hep-ex/9803006]

$$R_{\text{multi-GeV}}^{\text{SK}} = 0.66 \pm 0.06 \pm 0.08$$

[Super-Kamiokande, Phys. Lett. B 436 (1998) 33, hep-ex/9805006]

Super-Kamiokande Up-Down Asymmetry

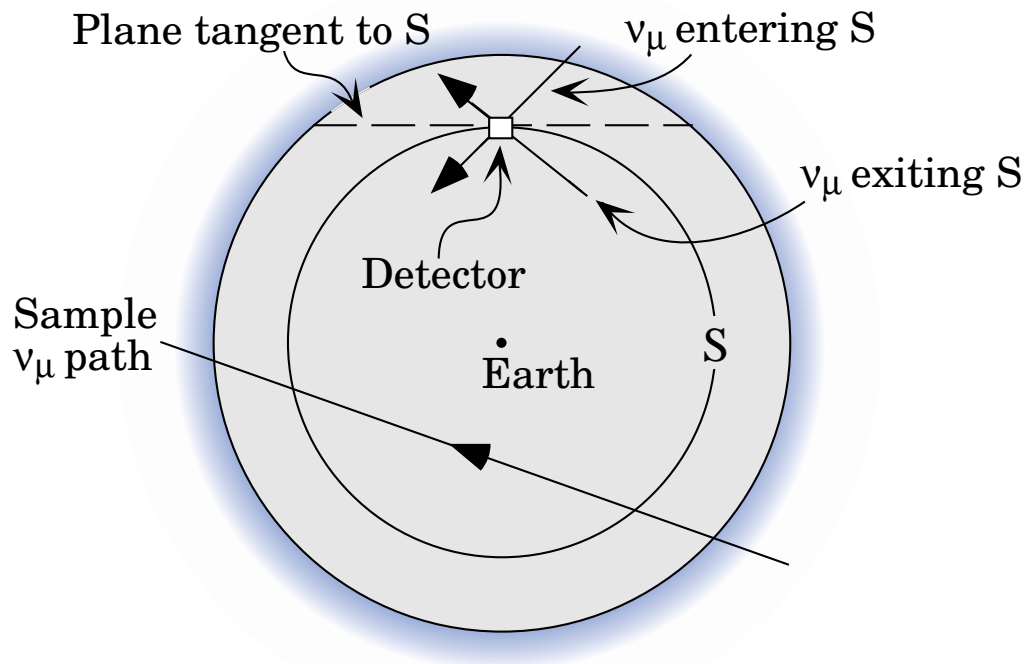

- any ν entering the sphere S later exits it
- steady state $\Rightarrow \Phi^{\text{in}}(S) = \Phi^{\text{out}}(S)$
- $E_\nu \gtrsim 1 \text{ GeV} \Rightarrow$ isotropic flux of cosmic rays
- homogeneity $\Rightarrow \Phi^{\text{in}}(s) = \Phi^{\text{out}}(s), \forall s \in S$
- $D \in S \Rightarrow \Phi^{\text{up}}(D) = \Phi^{\text{down}}(D),$

[B. Kayser, Review of Particle Properties, PRD 66 (2002) 010001]

$$A_{\nu_\mu}^{\text{up-down}}(\text{SK}) = \left(\frac{N_{\nu_\mu}^{\text{up}} - N_{\nu_\mu}^{\text{down}}}{N_{\nu_\mu}^{\text{up}} + N_{\nu_\mu}^{\text{down}}} \right) = -0.296 \pm 0.048 \pm 0.01$$

(December 1998)

[Super-Kamiokande, Phys. Rev. Lett. 81 (1998) 1562, hep-ex/9807003]

6 σ MODEL INDEPENDENT EVIDENCE OF ν_μ DISAPPEARANCE!

Super-Kamiokande Evidence of Oscillations

hep-ex/0404034, April 2004

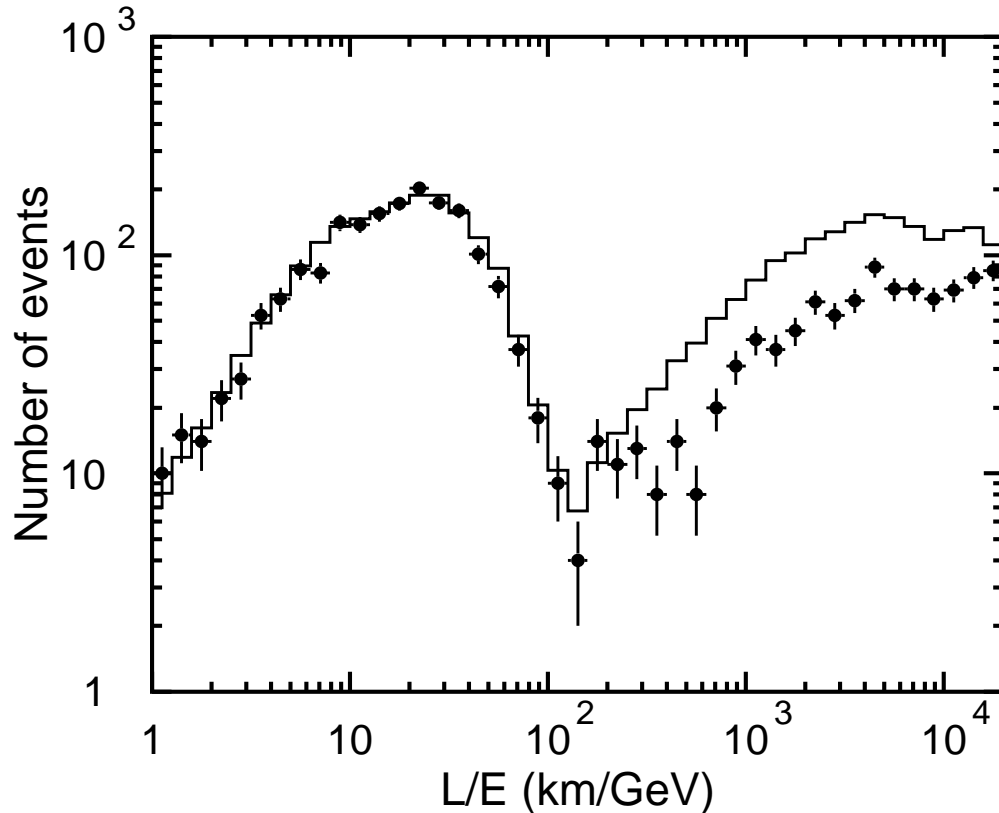

Number of events as a function of L/E for the data (points) and the atmospheric neutrino MC events without oscillations (histogram).

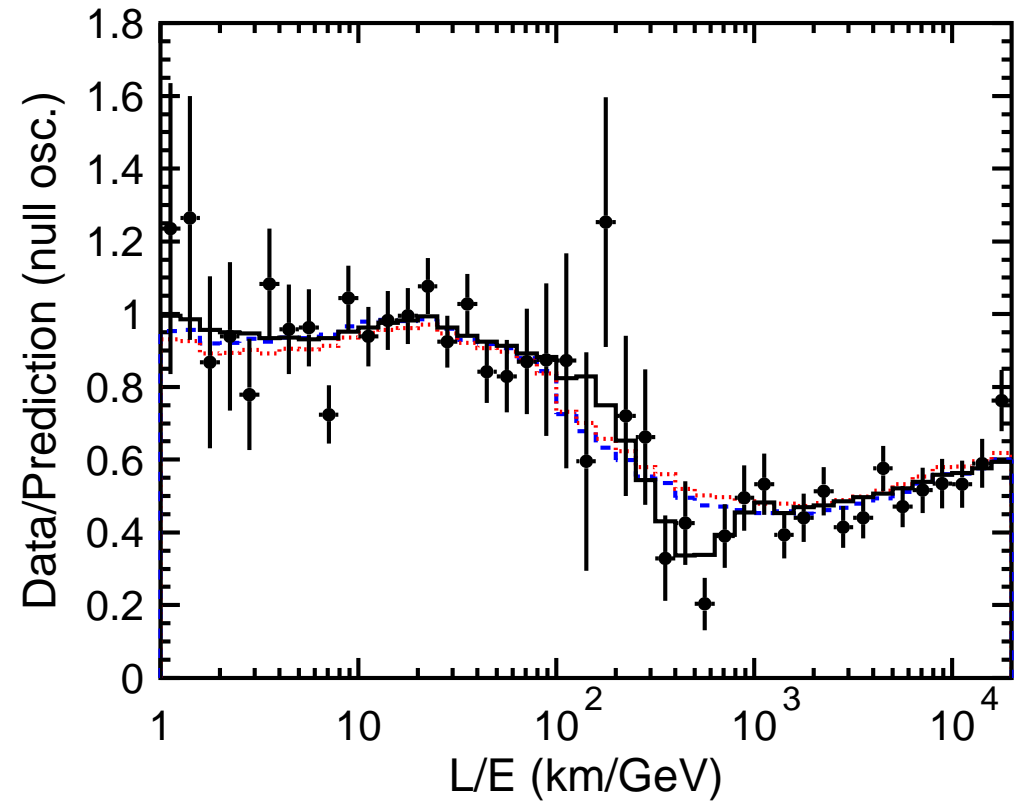

Ratio of the data to the MC events without neutrino oscillation (points) as a function of L/E together with the best-fit expectations for $\nu_\mu \rightarrow \nu_\tau$ oscillations (solid line), neutrino decay (dashed line) and neutrino decoherence (dotted line).

$\nu_\mu \rightarrow \nu_\tau$ Fit of Super-Kamiokande Atmospheric Data

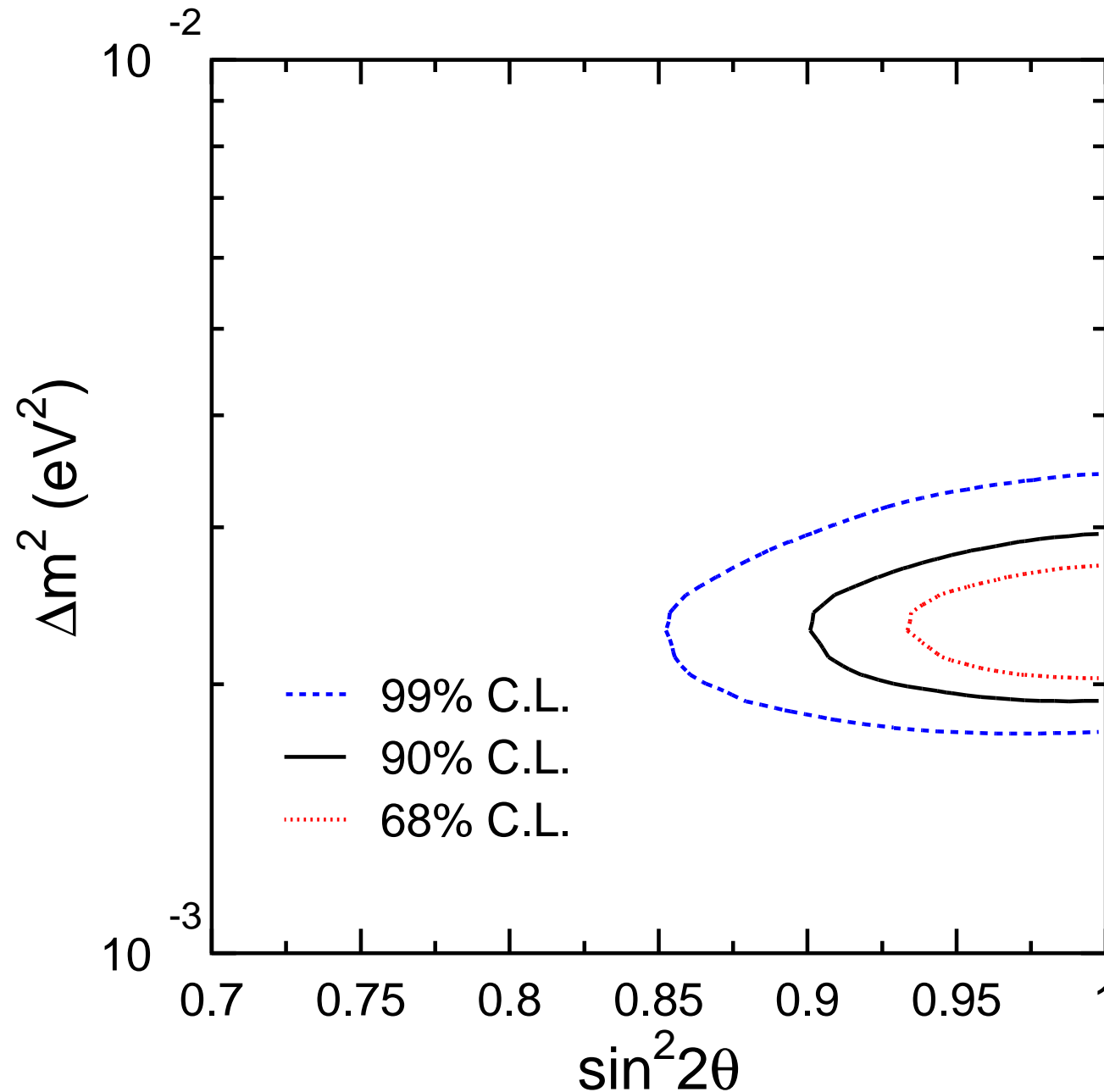

Best Fit:
 $\Delta m^2 = 2.4 \times 10^{-3} \text{ eV}^2$
 $\sin^2 2\theta = 1.0$

[Super-Kamiokande, hep-ex/0404034]

Soudan-2 & MACRO

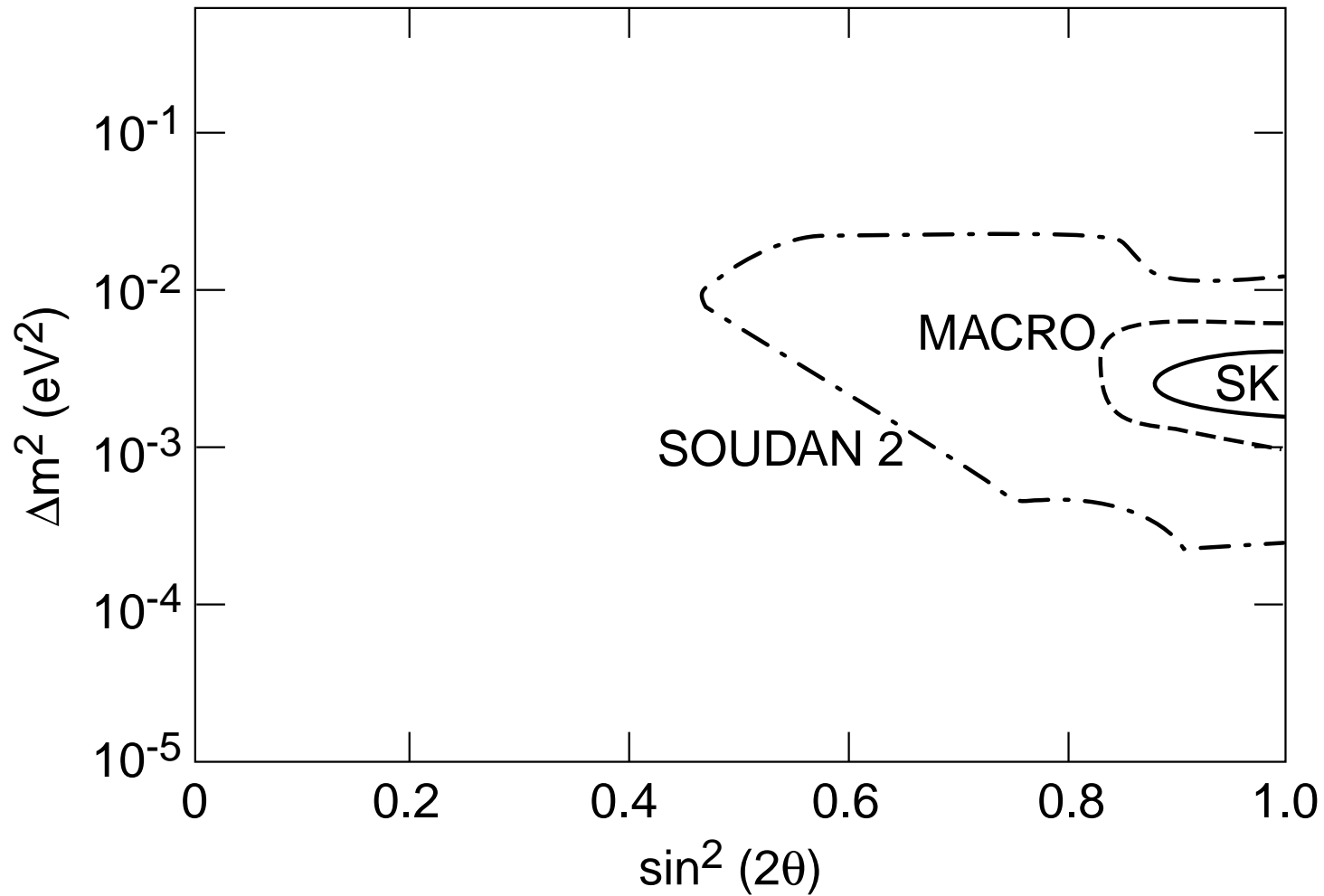

[Giacomelli, Giorgini, Spurio, hep-ex/0201032]

K2K

confirmation of atmospheric allowed region (June 2002)

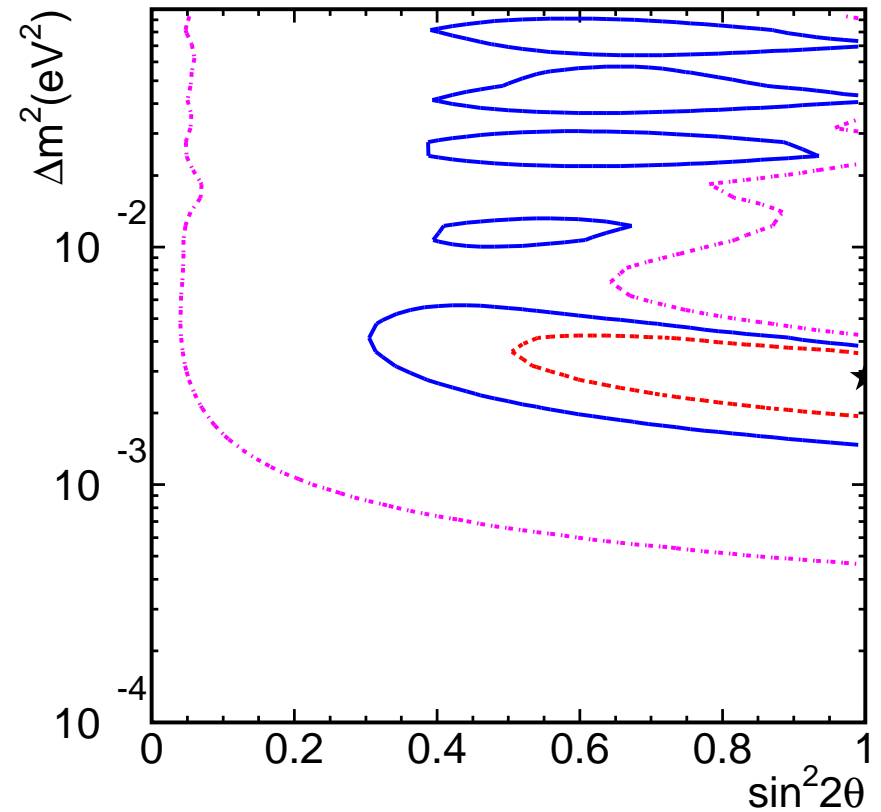
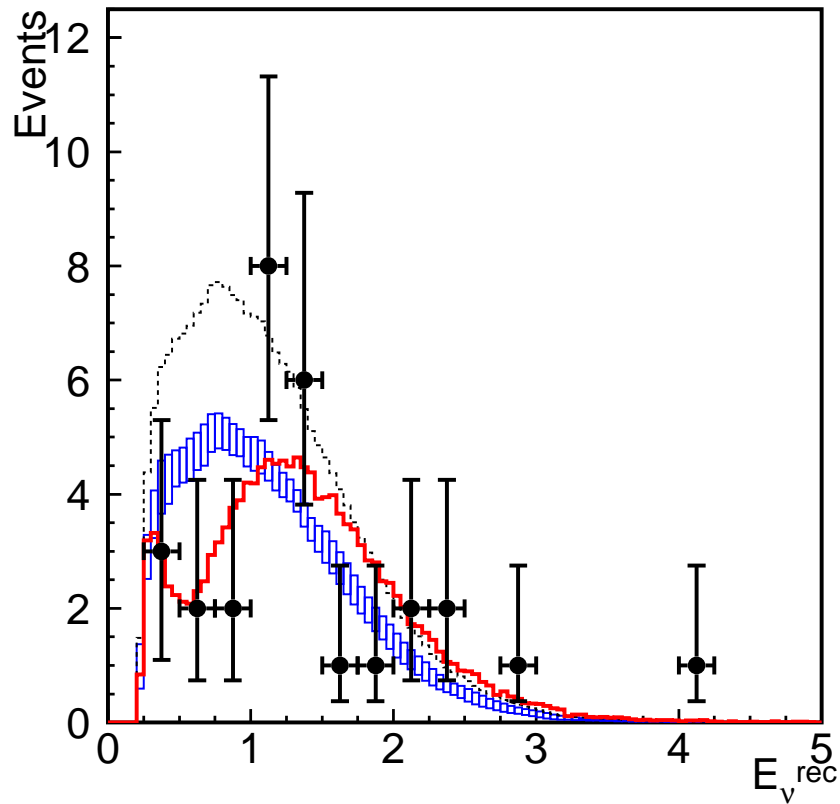
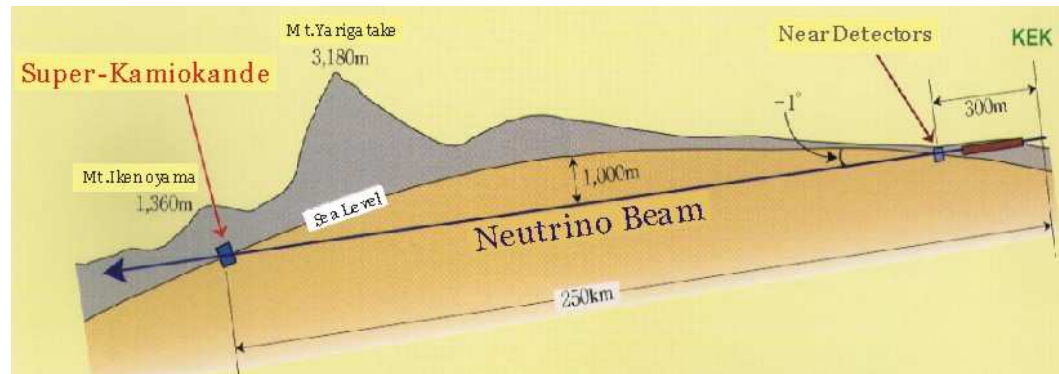

[K2K, Phys. Rev. Lett. 90 (2003) 041801]

K2K: Evidence of Spectral Distortion

<http://neutrino.kek.jp/news/2004.06.10/index-e.html>, June 2004

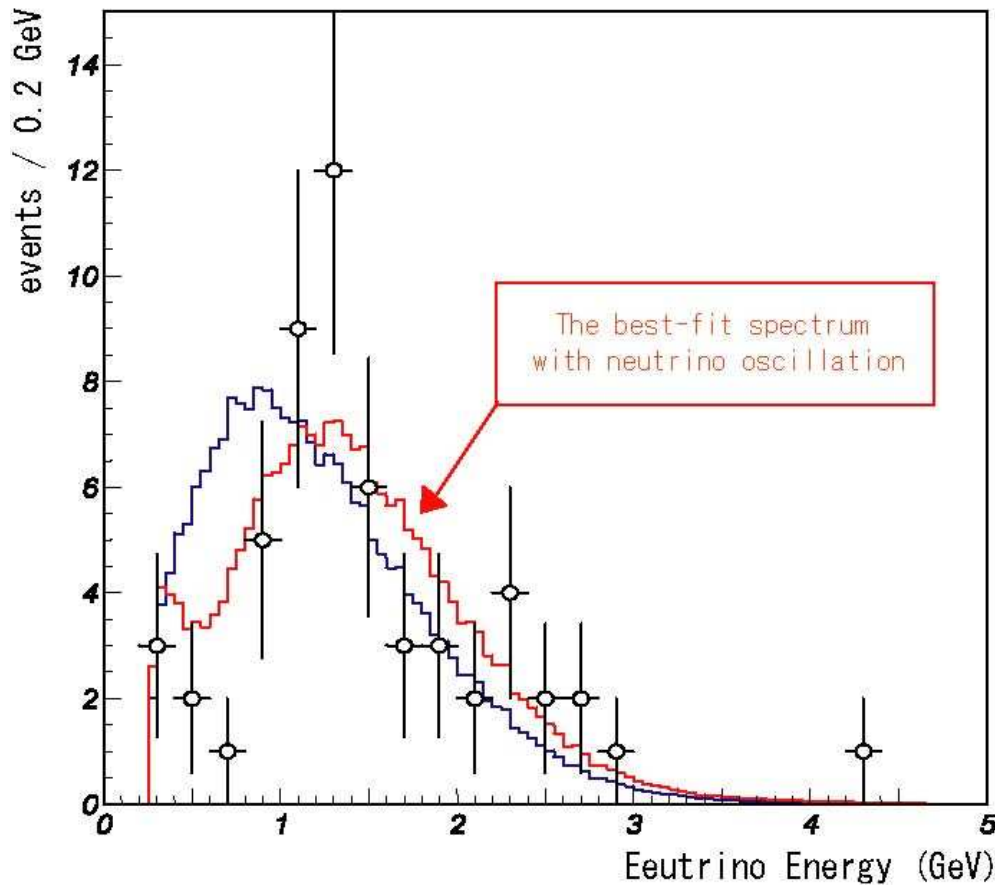

K2K energy spectrum (data points), compared to the scaled KEK beam spectrum (black histogram) and the best-fit expected spectrum taking into account neutrino oscillations (red histogram).

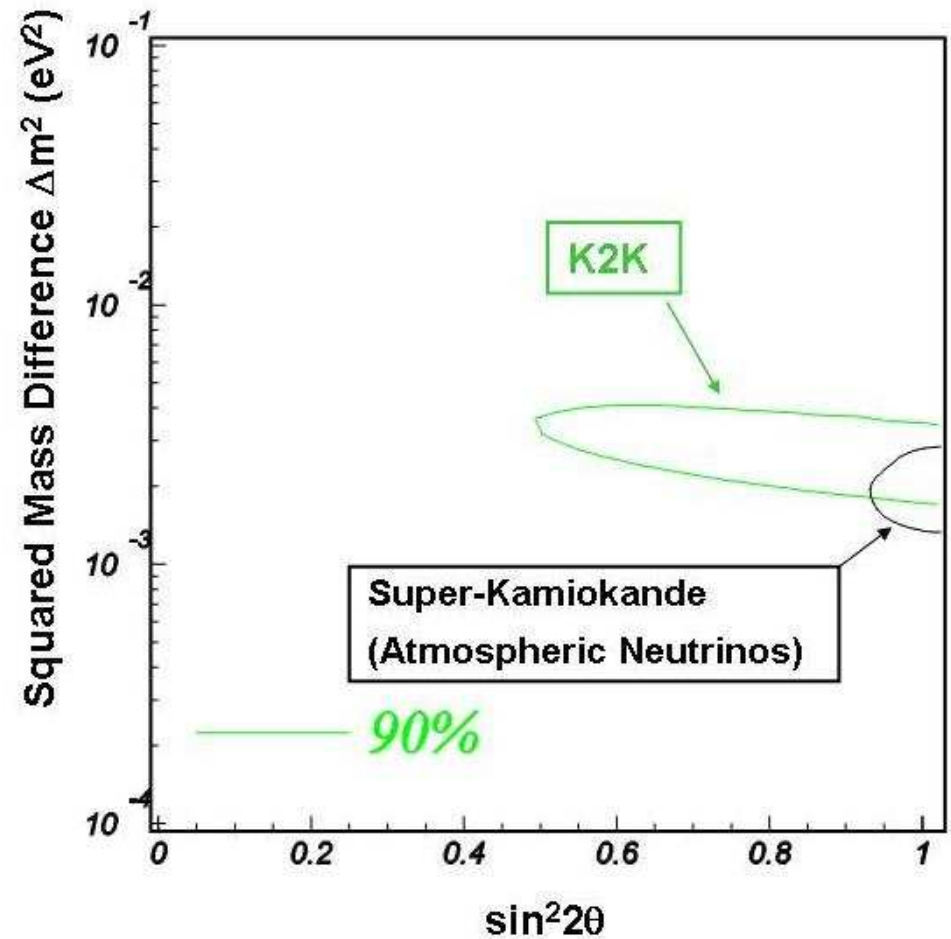

90% confidence regions for $\nu_\mu \rightarrow \nu_\tau$ oscillation from K2K (green) and Super-Kamiokande atmospheric neutrinos (black).

Experimental Evidences of Neutrino Oscillations

<p>Solar $\nu_e \rightarrow \nu_\mu, \nu_\tau$ $\left(\begin{array}{l} \text{Homestake, Kamiokande,} \\ \text{GALLEX, SAGE, GNO,} \\ \text{Super-Kamiokande, SNO} \end{array} \right)$</p> <p>Reactor $\bar{\nu}_e$ disappearance (KamLAND)</p>	}	⇒	$\Delta m_{\text{SUN}}^2 \text{ best-fit} = 8.2 \times 10^{-5}$ $7.4 \times 10^{-5} < \Delta m_{\text{SUN}}^2 < 9.2 \times 10^{-5}$ $[\text{eV}^2] \quad (3\sigma)$ <p>[Bahcall, Gonzalez-Garcia, Pena-Garay, hep-ph/0406294]</p>
<p>Atmospheric $\nu_\mu \rightarrow \nu_\tau$ $\left(\begin{array}{l} \text{Kamiokande, IMB,} \\ \text{Super-Kamiokande,} \\ \text{MACRO, SOUDAN 2} \end{array} \right)$</p> <p>Accelerator ν_μ disappearance (K2K)</p>	}	⇒	$\Delta m_{\text{ATM}}^2 \text{ best-fit} = 2.6 \times 10^{-3}$ $1.4 \times 10^{-3} < \Delta m_{\text{ATM}}^2 < 5.1 \times 10^{-3}$ $[\text{eV}^2] \quad (3\sigma)$ <p>[Fogli, Lisi, Marrone, Montanino, PRD 67 (2003) 093006]</p>

Three-Neutrino Mixing

flavor fields $\nu_\alpha, \alpha = e, \mu, \tau$ $\nu_{\alpha L} = \sum_{k=1}^3 U_{\alpha k} \nu_{kL}$ massive fields $\nu_k \rightarrow m_k$

$$\Delta m_{\text{SUN}}^2 = \Delta m_{21}^2 \qquad \Delta m_{\text{ATM}}^2 \simeq |\Delta m_{31}^2| \simeq |\Delta m_{32}^2|$$

Allowed Three-Neutrino Schemes

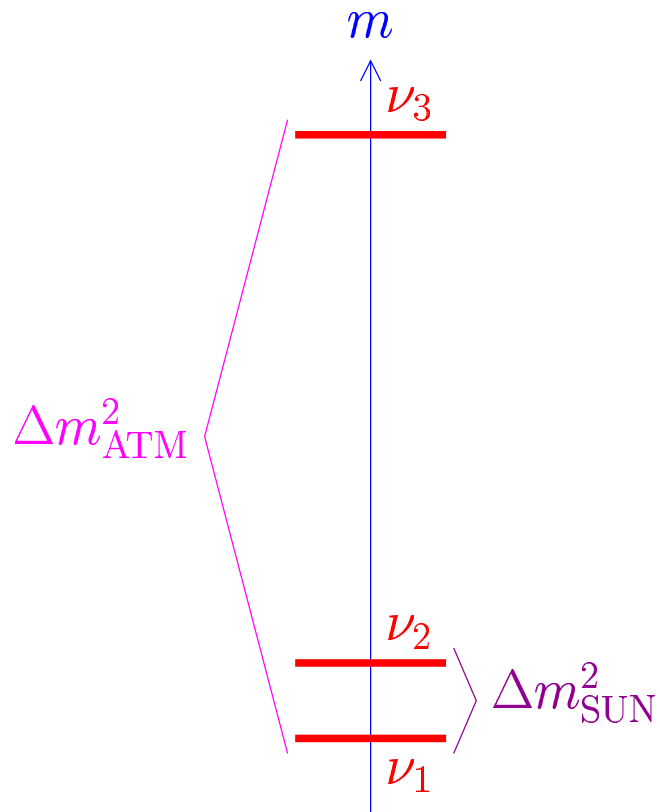

"normal"

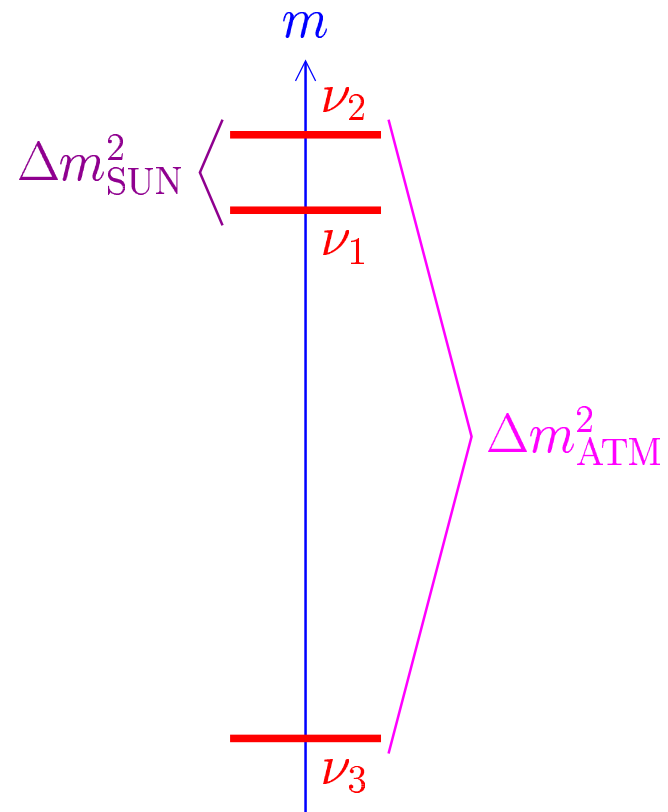

"inverted"

absolute scale is not determined by neutrino oscillation data

Standard Parameterization of Mixing Matrix

$$U = R_{23} W_{13} R_{12}$$

$$= \begin{pmatrix} 1 & 0 & 0 \\ 0 & c_{23} & s_{23} \\ 0 & -s_{23} & c_{23} \end{pmatrix} \begin{pmatrix} c_{13} & 0 & s_{13}e^{-i\delta_{13}} \\ 0 & 1 & 0 \\ -s_{13}e^{i\delta_{13}} & 0 & c_{13} \end{pmatrix} \begin{pmatrix} c_{12} & s_{12} & 0 \\ -s_{12} & c_{12} & 0 \\ 0 & 0 & 1 \end{pmatrix}$$

$\vartheta_{23} \simeq \vartheta_{\text{ATM}} \qquad \vartheta_{13} = \vartheta_{\text{CHOOZ}} \qquad \vartheta_{12} = \vartheta_{\text{SUN}}$

$$= \begin{pmatrix} c_{12}c_{13} & s_{12}c_{13} & s_{13}e^{-i\delta_{13}} \\ -s_{12}c_{23} - c_{12}s_{23}s_{13}e^{i\delta_{13}} & c_{12}c_{23} - s_{12}s_{23}s_{13}e^{i\delta_{13}} & s_{23}c_{13} \\ s_{12}s_{23} - c_{12}c_{23}s_{13}e^{i\delta_{13}} & -c_{12}s_{23} - s_{12}c_{23}s_{13}e^{i\delta_{13}} & c_{23}c_{13} \end{pmatrix}$$

$$\sin^2 \vartheta_{\text{CHOOZ}} = |U_{e3}|^2 = \sin^2 \vartheta_{13}$$

$$\sin^2 \vartheta_{\text{SUN}} = \frac{|U_{e2}|^2}{1 - |U_{e3}|^2} = \frac{s_{12}^2 c_{13}^2}{1 - s_{13}^2} = \sin^2 \vartheta_{12}$$

$$\sin^2 \vartheta_{\text{ATM}} = |U_{\mu 3}|^2 = s_{23}^2 c_{13}^2 \simeq \sin^2 \vartheta_{23}$$

Bilarge Mixing

$$|U_{e3}|^2 \ll 1 \Rightarrow U \simeq \begin{pmatrix} c_{\vartheta_S} & s_{\vartheta_S} & 0 \\ -s_{\vartheta_S} c_{\vartheta_A} & c_{\vartheta_S} c_{\vartheta_A} & s_{\vartheta_A} \\ s_{\vartheta_S} s_{\vartheta_A} & -c_{\vartheta_S} s_{\vartheta_A} & c_{\vartheta_A} \end{pmatrix} \Rightarrow \begin{cases} \nu_e = c_{\vartheta_S} \nu_1 + s_{\vartheta_S} \nu_2 \\ \nu_a^{(S)} = -s_{\vartheta_S} \nu_1 + c_{\vartheta_S} \nu_2 \\ \phantom{\nu_a^{(S)}} = c_{\vartheta_A} \nu_\mu - s_{\vartheta_A} \nu_\tau \end{cases}$$

$$\sin^2 2\vartheta_A \simeq 1 \Rightarrow \vartheta_A \simeq \frac{\pi}{4} \Rightarrow U \simeq \begin{pmatrix} c_{\vartheta_S} & s_{\vartheta_S} & 0 \\ -s_{\vartheta_S}/\sqrt{2} & c_{\vartheta_S}/\sqrt{2} & 1/\sqrt{2} \\ s_{\vartheta_S}/\sqrt{2} & -c_{\vartheta_S}/\sqrt{2} & 1/\sqrt{2} \end{pmatrix}$$

$$\text{Solar } \nu_e \rightarrow \nu_a^{(S)} \simeq \frac{1}{\sqrt{2}} (\nu_\mu - \nu_\tau)$$

$$\frac{\Phi_{\text{CC}}^{\text{SNO}}}{\Phi_{\nu_e}^{\text{SSM}}} \simeq \frac{1}{3} \Rightarrow \Phi_{\nu_e} \simeq \Phi_{\nu_\mu} \simeq \Phi_{\nu_\tau} \text{ for } E \gtrsim 6 \text{ MeV}$$

$$\text{LMA} \Rightarrow \tan^2 \vartheta_S \simeq 0.4 \Rightarrow \vartheta_S \simeq \frac{\pi}{6} \Rightarrow U \simeq \begin{pmatrix} \frac{\sqrt{3}}{2} & \frac{1}{2} & 0 \\ -\frac{1}{2\sqrt{2}} & \frac{\sqrt{3}}{2\sqrt{2}} & \frac{1}{\sqrt{2}} \\ \frac{1}{2\sqrt{2}} & -\frac{\sqrt{3}}{2\sqrt{2}} & \frac{1}{\sqrt{2}} \end{pmatrix}$$

Global Fit of Oscillation Data \Rightarrow BiLarge Mixing

[Fogli, Lisi, Marrone, Melchiorri, Palazzo, Serra, Silk, hep-ph/0408045]

$$\Delta m_{21}^{2\text{bf}} \simeq 8.3 \times 10^{-5} \text{ eV}^2 \quad 7.4 \times 10^{-5} \lesssim \Delta m_{21}^2 \lesssim 9.3 \times 10^{-5} \quad (3\sigma)$$

$$\Delta m_{31}^{2\text{bf}} \simeq 2.4 \times 10^{-3} \text{ eV}^2 \quad 1.8 \times 10^{-3} \lesssim \Delta m_{31}^2 \lesssim 3.2 \times 10^{-3} \quad (3\sigma)$$

$$\sin^2 \vartheta_{12}^{\text{bf}} \simeq 0.28 \quad 0.22 \lesssim \sin^2 \vartheta_{12} \lesssim 0.37 \quad (3\sigma)$$

$$\sin^2 \vartheta_{13}^{\text{bf}} \simeq 0.01 \quad \sin^2 \vartheta_{13} \lesssim 0.05 \quad (3\sigma)$$

$$\sin^2 2\vartheta_{\text{ATM}}^{\text{bf}} \simeq 1 \quad \sin^2 2\vartheta_{\text{ATM}} \gtrsim 0.86 \quad (3\sigma) \quad [\text{Fogli, Lisi, Marrone, Montanino, PRD 67 (2003) 093006}]$$

$$\sin^2 \vartheta_{\text{ATM}} = |U_{\mu 3}|^2 = \sin^2 \vartheta_{23} \cos^2 \vartheta_{13}$$

$ U _{\text{bf}} \simeq \begin{pmatrix} 0.84 & 0.53 & 0.10 \\ 0.31 - 0.43 & 0.56 - 0.63 & 0.71 \\ 0.32 - 0.44 & 0.57 - 0.64 & 0.70 \end{pmatrix}$	$ U \simeq \begin{pmatrix} 0.77 - 0.88 & 0.46 - 0.61 & 0.00 - 0.22 \\ 0.08 - 0.60 & 0.30 - 0.79 & 0.55 - 0.85 \\ 0.10 - 0.61 & 0.33 - 0.81 & 0.51 - 0.83 \end{pmatrix}$
---	--

Open Questions on Neutrino Masses

Value of $ U_{e3} , J_{CP}$?	←	ν Oscillations
Sterile Neutrinos?	←	ν Oscillations
		LSND indication \Rightarrow wait MiniBooNE
Absolute Scale of Neutrino Masses?	←	β Decay, Cosmology, $\beta\beta_{0\nu}$ Decay
Pattern of Neutrino Masses?	←	ν Osc., β Dec., Cosmology, $\beta\beta_{0\nu}$ Dec.
Are Neutrinos Majorana?	←	$\beta\beta_{0\nu}$ Decay

Oscillations are Insensitive to Absolute Scale of Neutrino Masses

oscillations are due to the interference of different massive components of a flavor ν



oscillations can be sensitive only to mass differences

In Neutrino Oscillations Dirac = Majorana

$$\frac{d\nu_\alpha}{dt} = \frac{1}{2E} \left(U M^2 U^\dagger + 2EV \right)_{\alpha\beta} \nu_\beta \quad M^2 = \text{diag}(m_1^2, m_2^2, m_3^2)$$

Dirac: $U \rightarrow U_D$

Majorana: $U \rightarrow U_M = U_D D$

$$U_D = \begin{pmatrix} c_{12}c_{13} & s_{12}c_{13} & s_{13}e^{-i\delta} \\ -s_{12}c_{23} - c_{12}s_{23}s_{13}e^{i\delta} & c_{12}c_{23} - s_{12}s_{23}s_{13}e^{i\delta} & s_{23}c_{13} \\ s_{12}s_{23} - c_{12}c_{23}s_{13}e^{i\delta} & -c_{12}s_{23} - s_{12}c_{23}s_{13}e^{i\delta} & c_{23}c_{13} \end{pmatrix}$$

$$D = \text{diag}(1, e^{i\lambda_{21}}, e^{i\lambda_{31}}) \Rightarrow U_M M^2 U_M^\dagger = U_D D M^2 D^\dagger U_D^\dagger = U_D M^2 U_D^\dagger$$

Majorana phases

[Bilenky, Hosek, Petcov, PLB 94 (1980) 495]

[Doi, Kotani, Nishiura, Okuda, Takasugi, PLB 102 (1981) 323]

[Langacker, Petcov, Steigman, Toshev, NPB 282 (1987) 589]

Absolute Scale of Neutrino Masses

normal scheme

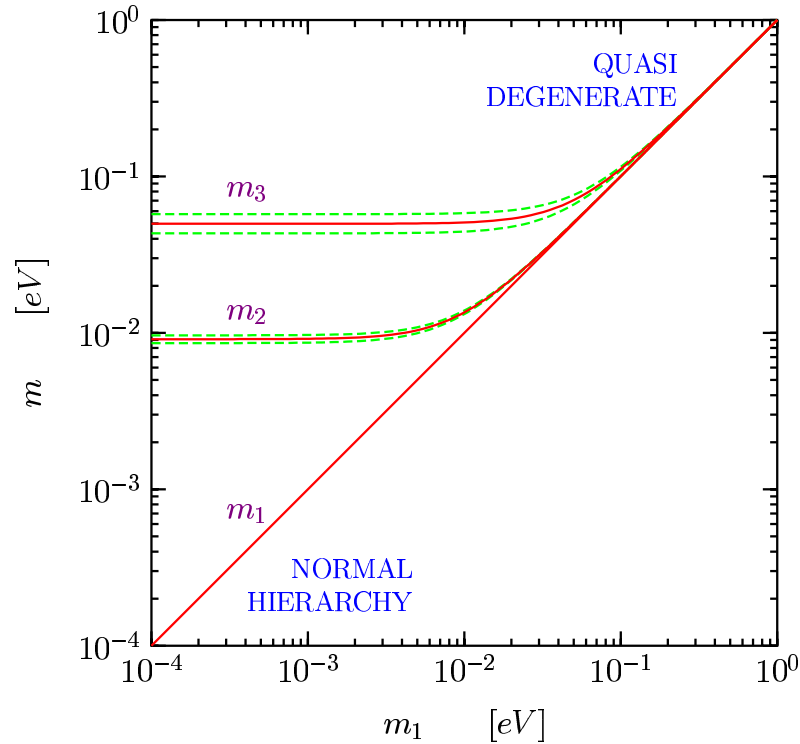

inverted scheme

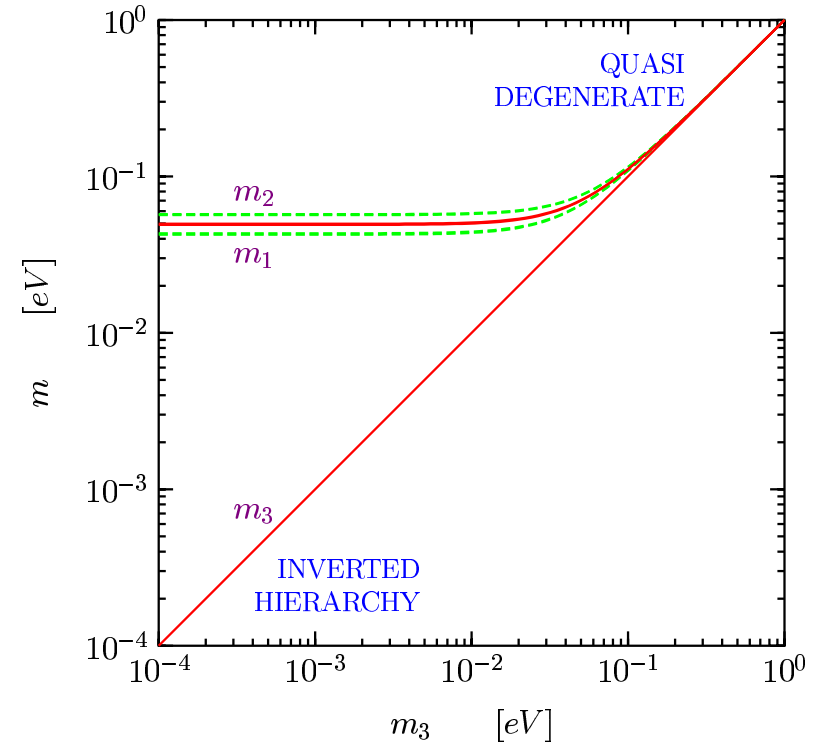

$$m_2^2 = m_1^2 + \Delta m_{21}^2 = m_1^2 + \Delta m_{\text{SUN}}^2$$

$$m_3^2 = m_1^2 + \Delta m_{31}^2 = m_1^2 + \Delta m_{\text{ATM}}^2$$

$$m_1^2 = m_3^2 - \Delta m_{31}^2 = m_3^2 + \Delta m_{\text{ATM}}^2$$

$$m_2^2 = m_1^2 + \Delta m_{21}^2 \simeq m_3^2 + \Delta m_{\text{ATM}}^2$$

Quasi Degenerate for $m_1 \simeq m_2 \simeq m_3 \simeq m_\nu \gg \sqrt{\Delta m_{\text{ATM}}^2} \simeq 5 \times 10^{-2} \text{ eV}$

Tritium β Decay



$$\frac{d\Gamma}{dT} = \frac{(\cos\vartheta_C G_F)^2}{2\pi^3} |\mathcal{M}|^2 F(E) pE (Q - T) \sqrt{(Q - T)^2 - m_{\nu_e}^2}$$

$$Q = M_{{}^3\text{H}} - M_{{}^3\text{He}} - m_e = 18.58 \text{ keV}$$

Kurie plot:
$$K(T) = \sqrt{\frac{d\Gamma/dT}{\frac{(\cos\vartheta_C G_F)^2}{2\pi^3} |\mathcal{M}|^2 F(E) pE}} = \left[(Q - T) \sqrt{(Q - T)^2 - m_{\nu_e}^2} \right]^{1/2}$$

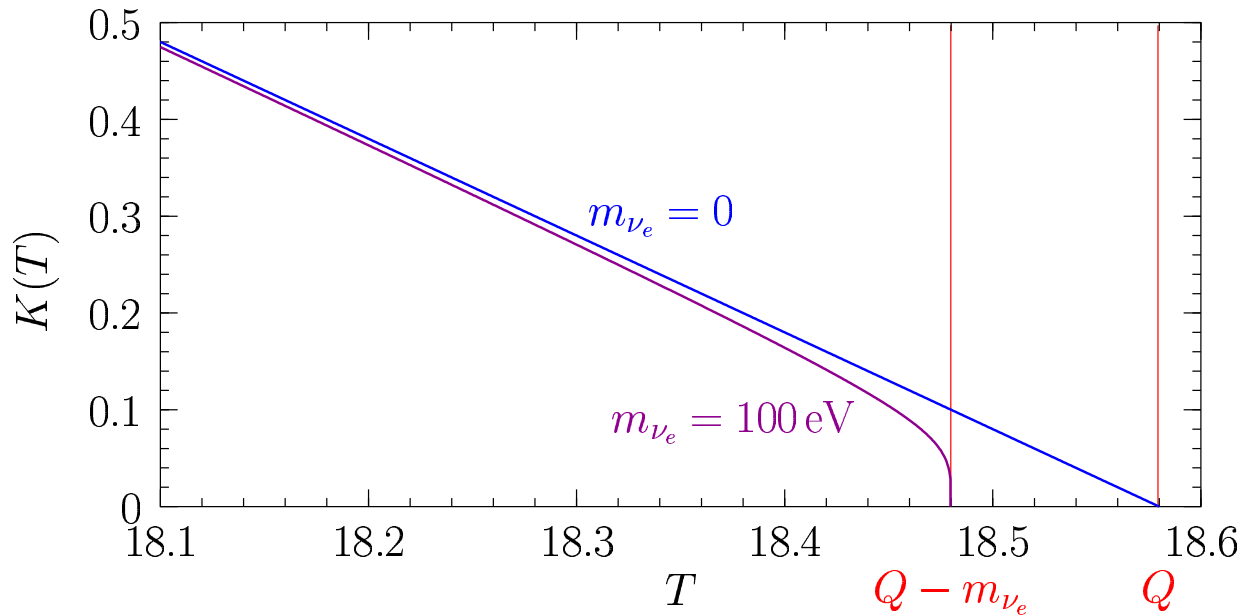

$m_{\nu_e} < 2.2 \text{ eV} \quad (95\% \text{ C.L.})$

Mainz & Troitsk [Weinheimer, hep-ex/0210050]

$m_{\nu_e} < 1.8 \text{ eV} \quad (95\% \text{ C.L.})$

Mainz + Troitsk [Fogli et al., hep-ph/0408045]

future: KATRIN

[hep-ex/0109033] [hep-ex/0309007]

sensitivity: $m_{\nu_e} \simeq 0.2 - 0.3 \text{ eV}$

Neutrino Mixing $\Rightarrow K(T) = \left[(Q - T) \sum_k |U_{ek}|^2 \sqrt{(Q - T)^2 - m_k^2} \right]^{1/2}$

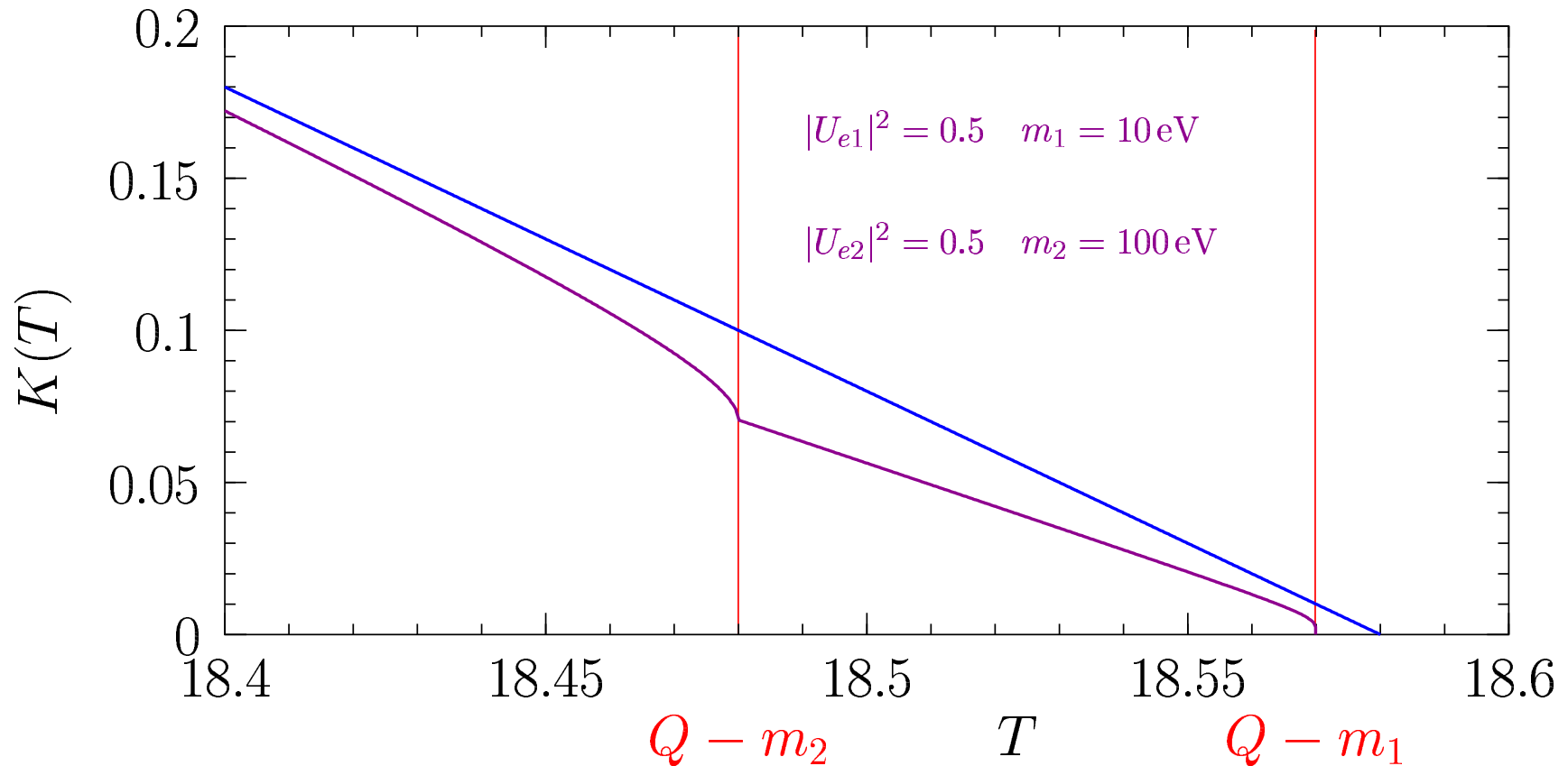

analysis of data is different from the no-mixing case

$2N - 1$ parameters = N masses + $N - 1$ mixing matrix elements $\left(\sum_k |U_{ek}|^2 = 1 \right)$

if experiment is not sensitive to masses ($m_k \ll Q - T$) \implies effective mass

$$m_\beta^2 = \sum_k |U_{ek}|^2 m_k^2$$

[McKellar, PLB 97 (1980) 93] [Shrock, PLB 96 (1980) 159]

[Kobzarev, Martemyanov, Okun, Shchepkin, SJNP 32 (1980) 823]

[Holzschuh, RPP 55 (1992) 1035] [Weinheimer et al., PLB 460 (1999) 219]

[Vissani, NPB PS 100 (2001) 273 (NOW 2000)] [Farzan, Smirnov, PLB 557 (2003) 224]

$$\begin{aligned} K^2 &= (Q - T) \sum_k |U_{ek}|^2 \sqrt{(Q - T)^2 - m_k^2} = (Q - T)^2 \sum_k |U_{ek}|^2 \sqrt{1 - \frac{m_k^2}{(Q - T)^2}} \\ &\simeq (Q - T)^2 \sum_k |U_{ek}|^2 \left[1 - \frac{1}{2} \frac{m_k^2}{(Q - T)^2} \right] = (Q - T)^2 \left[1 - \frac{1}{2} \frac{m_\beta^2}{(Q - T)^2} \right] \\ &\simeq (Q - T)^2 \sqrt{1 - \frac{m_\beta^2}{(Q - T)^2}} = (Q - T) \sqrt{(Q - T)^2 - m_\beta^2} \end{aligned}$$

$$m_{\nu_e} < 2.2 \text{ eV} \quad (95\% \text{ C.L.}) \quad \implies \quad m_\beta < 2.2 \text{ eV} \quad (95\% \text{ C.L.})$$

Three-Neutrino Mixing \implies
$$m_\beta^2 = c_{12}^2 c_{13}^2 m_1^2 + s_{12}^2 c_{13}^2 m_2^2 + s_{13}^2 m_3^2$$

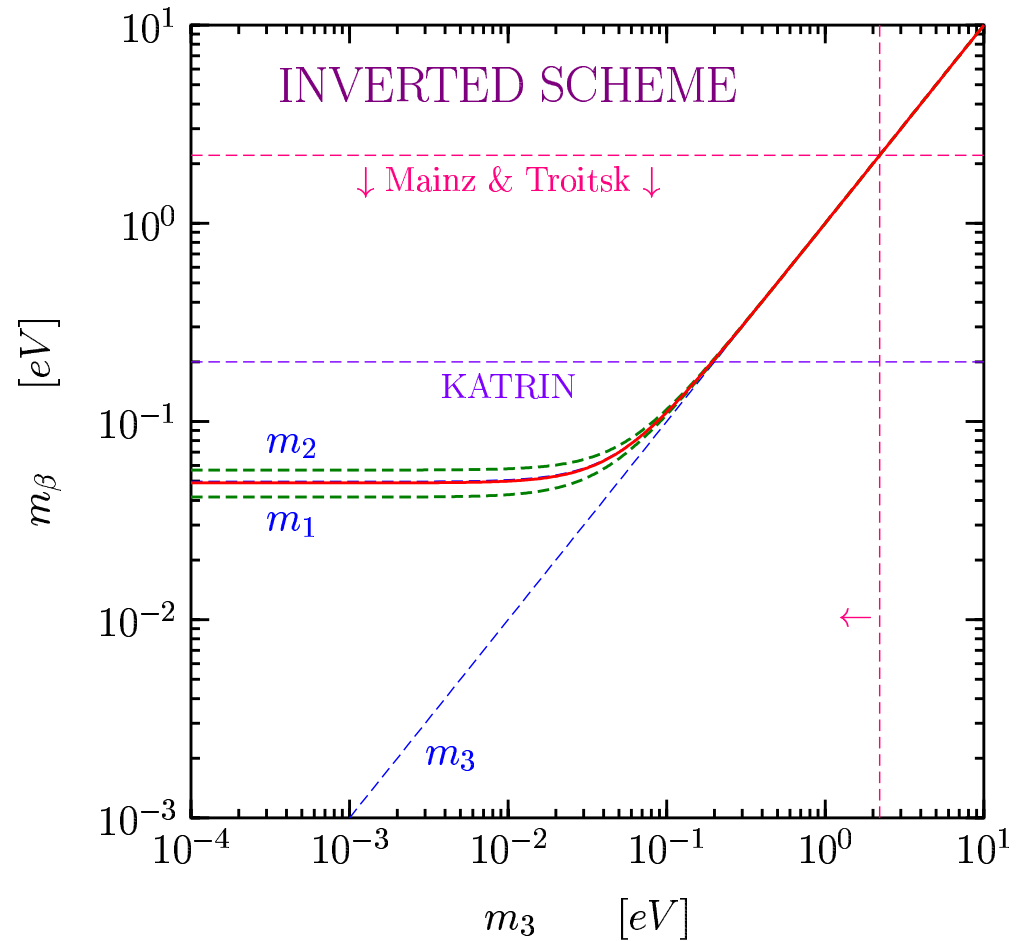
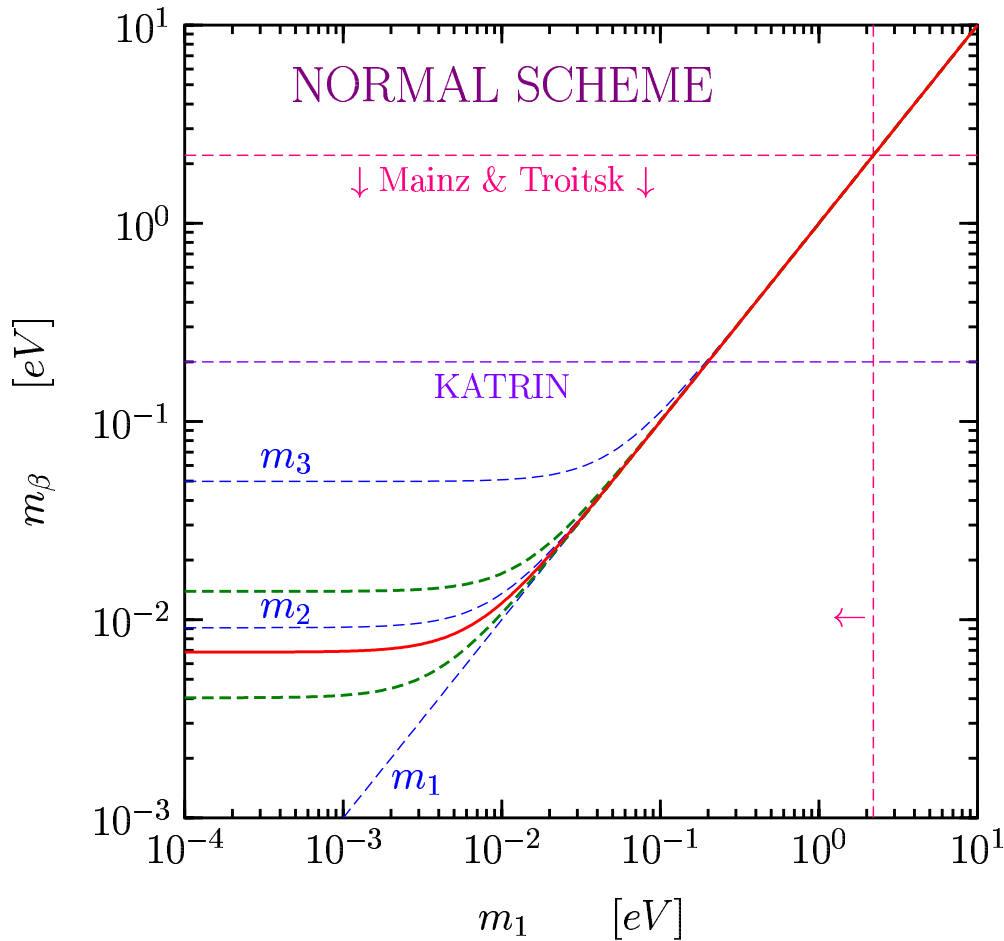

$$\begin{aligned}
 m_2^2 &= m_1^2 + \Delta m_{21}^2 = m_1^2 + \Delta m_{\text{SUN}}^2 \\
 m_3^2 &= m_1^2 + \Delta m_{31}^2 = m_1^2 + \Delta m_{\text{ATM}}^2 \\
 m_\beta^2 &\simeq m_1^2 + |U_{e2}|^2 \Delta m_{\text{SUN}}^2 + |U_{e3}|^2 \Delta m_{\text{ATM}}^2
 \end{aligned}$$

Quasi Degenerate: $m_1 \simeq m_2 \simeq m_3 \simeq m_\nu$

$$\begin{aligned}
 m_1^2 &= m_3^2 - \Delta m_{31}^2 = m_3^2 + \Delta m_{\text{ATM}}^2 \\
 m_2^2 &= m_1^2 + \Delta m_{21}^2 \simeq m_3^2 + \Delta m_{\text{ATM}}^2 \\
 m_\beta^2 &\simeq m_3^2 + (|U_{e1}|^2 + |U_{e2}|^2) \Delta m_{\text{ATM}}^2 \\
 &\Rightarrow m_\beta^2 \simeq m_\nu^2 \sum_k |U_{ek}|^2 = m_\nu^2
 \end{aligned}$$

FUTURE: IF $m_\beta \lesssim 4 \times 10^{-2} \text{ eV} \Rightarrow$ NORMAL HIERARCHY

Cosmological Bound on Neutrino Masses

neutrinos are in equilibrium in the primeval plasma through weak interaction reactions



weak interactions freeze out

$$\Gamma_{\text{weak}} = N\sigma v \sim G_F^2 T^5 \sim T^2/M_P \sim \sqrt{G_N T^4} \sim \sqrt{G_N \rho} \sim H \quad \Longrightarrow \quad T_{\text{dec}} \sim 1 \text{ MeV}$$

neutrino decoupling

Relic Neutrinos: $T_\nu = \left(\frac{4}{11}\right)^{\frac{1}{3}} T_\gamma \simeq 1.945 \text{ K} \Longrightarrow k T_\nu \simeq 1.676 \times 10^{-4} \text{ eV}$ ($T_\gamma = 2.725 \pm 0.001 \text{ K}$)

number density: $n_f = \frac{3}{4} \frac{\zeta(3)}{\pi^2} g_f T_f^3 \Longrightarrow n_{\nu_k, \bar{\nu}_k} \simeq 0.1827 T_\nu^3 \simeq 112 \text{ cm}^{-3}$

density contribution: $\Omega_k = \frac{n_{\nu_k, \bar{\nu}_k} m_k}{\rho_c} \simeq \frac{1}{h^2} \frac{m_k}{94.14 \text{ eV}} \Longrightarrow \Omega_\nu h^2 = \frac{\sum_k m_k}{94.14 \text{ eV}}$ ($\rho_c = \frac{3H^2}{8\pi G_N}$)

[Gershtein, Zeldovich, JETP Lett. 4 (1966) 120] [Cowsik, McClelland, PRL 29 (1972) 669]

$$h \sim 0.7, \quad \Omega_\nu \lesssim 1 \quad \Longrightarrow \quad \sum_k m_k \lesssim 46 \text{ eV}$$

Power Spectrum of Density Fluctuations

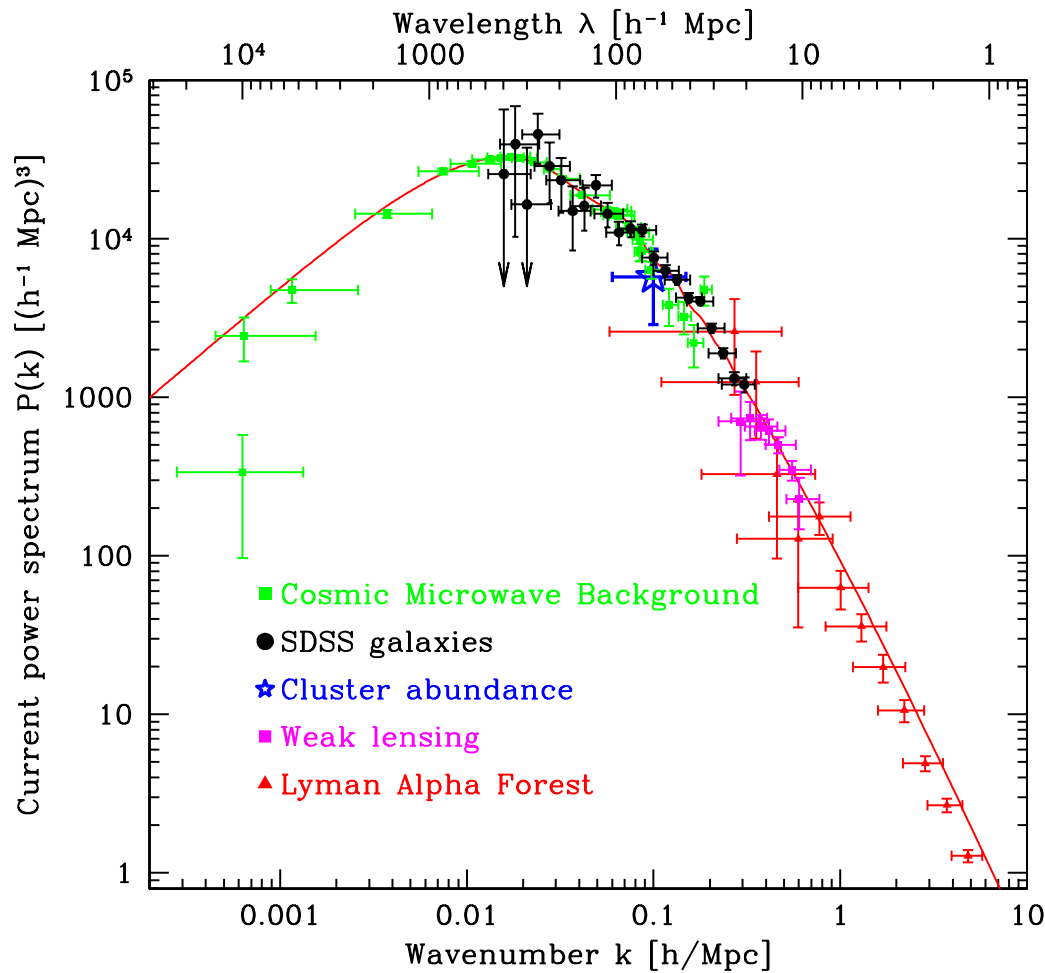

[SDSS, astro-ph/0310725]

Reviews: [Dolgov, Phys. Rept. 370 (2002) 33], [Kainulainen, Olive, hep-ph/0206163], [Sarkar, hep-ph/0302175], [Hannestad, NJP 6 (2004) 108]

hot dark matter prevents early galaxy formation

small scale suppression

$$\frac{\Delta P(k)}{P(k)} \approx -8 \frac{\Omega_\nu}{\Omega_m} \approx -0.8 \left(\frac{\sum_k m_k}{1 \text{ eV}} \right) \left(\frac{0.1}{\Omega_m h^2} \right)$$

$$\text{for } k \gtrsim k_{\text{nr}} \approx 0.026 \sqrt{\frac{m_\nu}{1 \text{ eV}}} \sqrt{\Omega_m} h \text{ Mpc}^{-1}$$

[Hu, Eisenstein, Tegmark, PRL 80 (1998) 5255]

CMB (WMAP, CBI, ACBAR) + LSS (2dFGRS) + Ly α + HST + SN-Ia

$$\Lambda\text{CDM: } \left\{ \begin{array}{lll} T_0 = 13.7 \pm 0.1 \text{ Gyr} & h = 0.71^{+0.04}_{-0.03}, \\ \Omega_{\text{tot}} = 1.02 \pm 0.02 & \Omega_b h^2 = 0.0224 \pm 0.0009 & \Omega_m h^2 = 0.135^{+0.008}_{-0.009} \end{array} \right.$$

$$\Omega_\nu h^2 < 0.0076 \quad (95\% \text{ confidence}) \quad \Rightarrow \quad \sum_k m_k < 0.71 \text{ eV}$$

Hannestad, JCAP 0305 (2003) 004

$\sum_k m_k < 1.01 \text{ eV}$	(95% confidence)	WMAP+CBI+2dFGRS+HST+SN-Ia
$\sum_k m_k < 1.20 \text{ eV}$	(95% confidence)	WMAP+CBI+2dFGRS
$\sum_k m_k < 2.12 \text{ eV}$	(95% confidence)	WMAP+2dFGRS

Elgaroy and Lahav, JCAP 04 (2003) 004

$$\sum_k m_k < 1.1 \text{ eV} \quad (95\% \text{ confidence}) \quad \text{WMAP+2dFGRS+HST}$$

SDSS, PRD 69 (2004) 103501

CMB(WMAP)+LSS(SDSS)+SN-Ia

$$h = 0.70^{+0.04}_{-0.03} \quad \Omega_m = 0.30 \pm 0.04 \quad \sum_k m_k < 1.7 \text{ eV} \quad (95\% \text{ confidence})$$

SDSS, astro-ph/0406594

CMB(WMAP)+LSS(SDSS)+bias(SDSS) $P_g(k) = b^2 P_m(k)$

$$\Omega_m = 0.25 \pm 0.03 \quad \sum_k m_k < 0.54 \text{ eV} \quad (95\% \text{ confidence})$$

SDSS, astro-ph/0407372

CMB(WMAP)+LSS(SDSS)+bias(SDSS)+Ly α (SDSS)+SN-Ia

$$\Omega_\Lambda = 0.72 \pm 0.02 \quad \sum_k m_k < 0.42 \text{ eV} \quad (95\% \text{ confidence})$$

Fogli, Lisi, Marrone, Melchiorri, Palazzo, Serra, Silk, hep-ph/0408045

$$\sum_k m_k < 1.4 \text{ eV} \quad (2\sigma) \quad \text{CMB+LSS+HST+SN-Ia}$$

$$\sum_k m_k < 0.47 \text{ eV} \quad (2\sigma) \quad \text{CMB+LSS+HST+SN-Ia+Ly}\alpha(\text{SDSS})$$

Approximate Estimate

$$\sum_k m_k \lesssim 1 \text{ eV} \quad (\sim 2\sigma)$$

CMB+LSS+HST+SN-Ia

$$\sum_k m_k \lesssim 0.5 \text{ eV} \quad (\sim 2\sigma)$$

CMB+LSS+HST+SN-Ia+Ly α

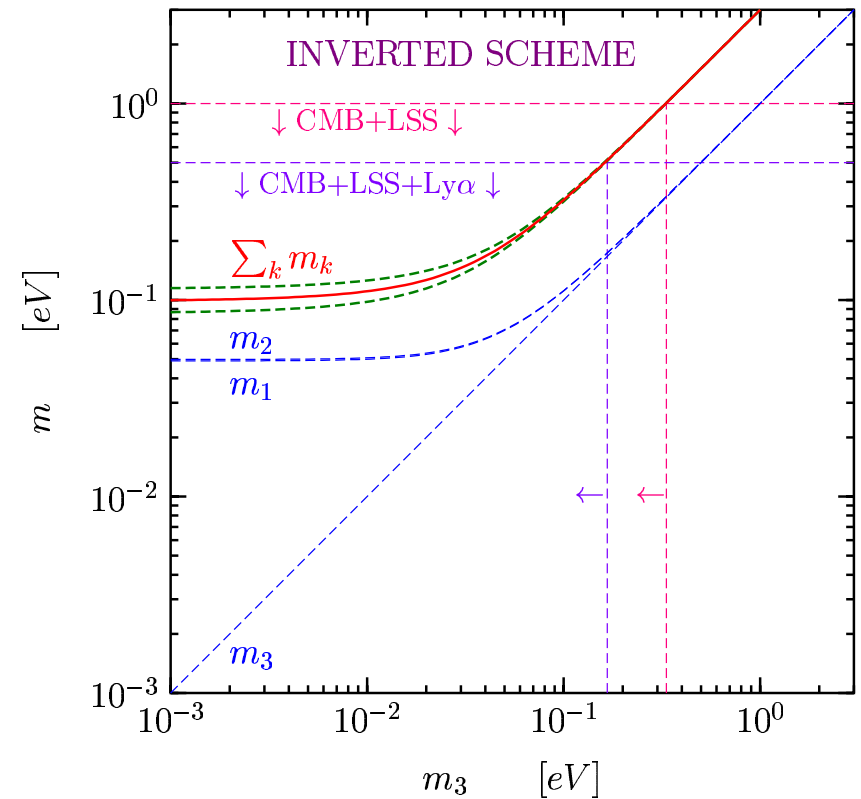
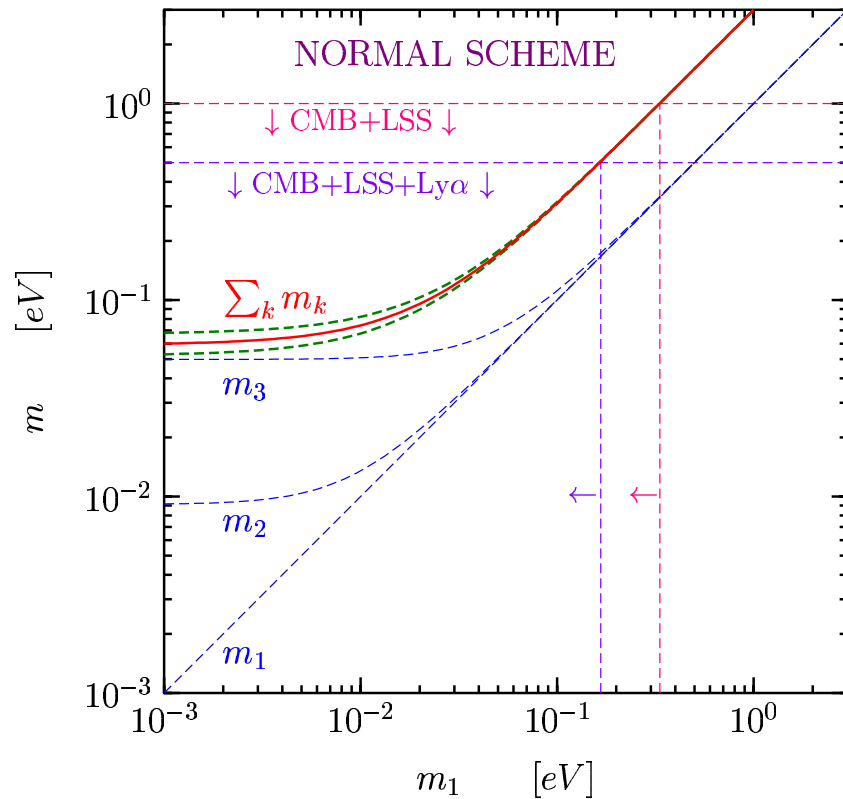

FUTURE: IF $\sum_k m_k \lesssim 8 \times 10^{-2} \text{ eV} \implies$ NORMAL HIERARCHY

Majorana Neutrino Mass?

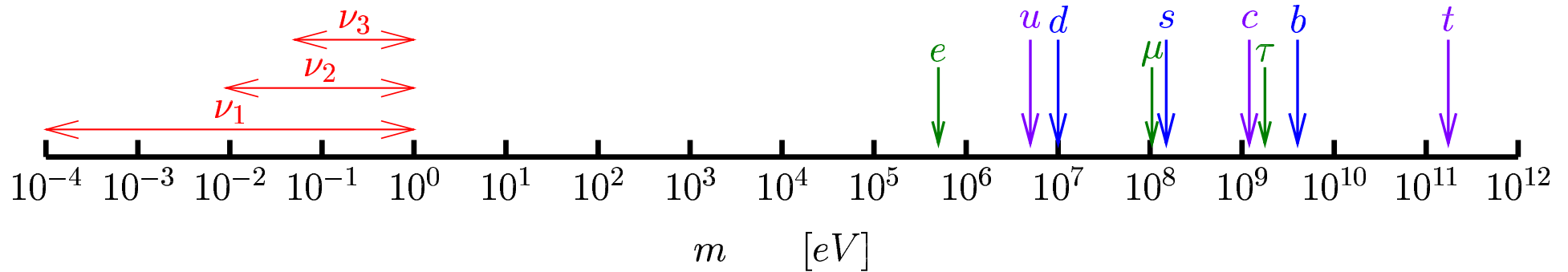

known natural explanations of smallness of ν masses: $\left\{ \begin{array}{l} \star \text{ See-Saw Mechanism} \\ \star \text{ 5-D Non-Renormalizable Effective Operator} \end{array} \right.$

both imply $\left\{ \begin{array}{l} \star \text{ Majorana } \nu \text{ masses } \iff |\Delta L| = 2 \iff \beta\beta_{0\nu} \text{ decay} \\ \star \text{ see-saw type relation } m_\nu \sim \frac{\mathcal{M}_{EW}^2}{\mathcal{M}} \\ \star \text{ new high energy scale } \mathcal{M} \end{array} \right.$

Majorana neutrino masses provide the most accessible window on New Physics Beyond the Standard Model

Two-Neutrino Double- β Decay: $\Delta L = 0$

$$\mathcal{N}(A, Z) \rightarrow \mathcal{N}(A, Z + 2) + e^- + e^- + \bar{\nu}_e + \bar{\nu}_e$$

$$(T_{1/2}^{2\nu})^{-1} = G_{2\nu} |\mathcal{M}_{2\nu}|^2$$

second order weak interaction process
in the Standard Model

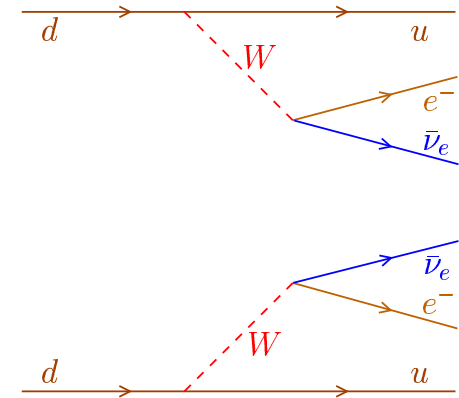

Neutrinoless Double- β Decay: $\Delta L = 2$

$$\mathcal{N}(A, Z) \rightarrow \mathcal{N}(A, Z + 2) + e^- + e^-$$

$$(T_{1/2}^{0\nu})^{-1} = G_{0\nu} |\mathcal{M}_{0\nu}|^2 |m_{\beta\beta}|^2$$

effective
Majorana
mass

$$m_{\beta\beta} = \sum_k U_{ek}^2 m_k$$

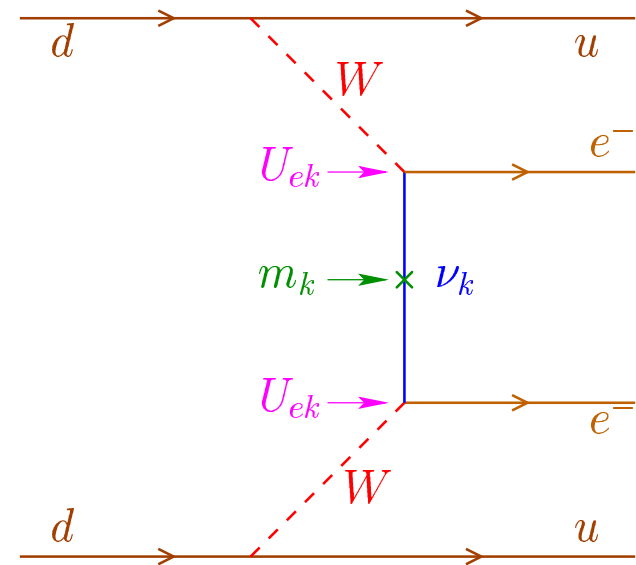

Majorana Neutrino Mass $\Leftrightarrow \beta\beta_{0\nu}$ Decay

[Schechter, Valle, PRD 25 (1982) 2951] [Takasugi, PLB 149 (1984) 372]

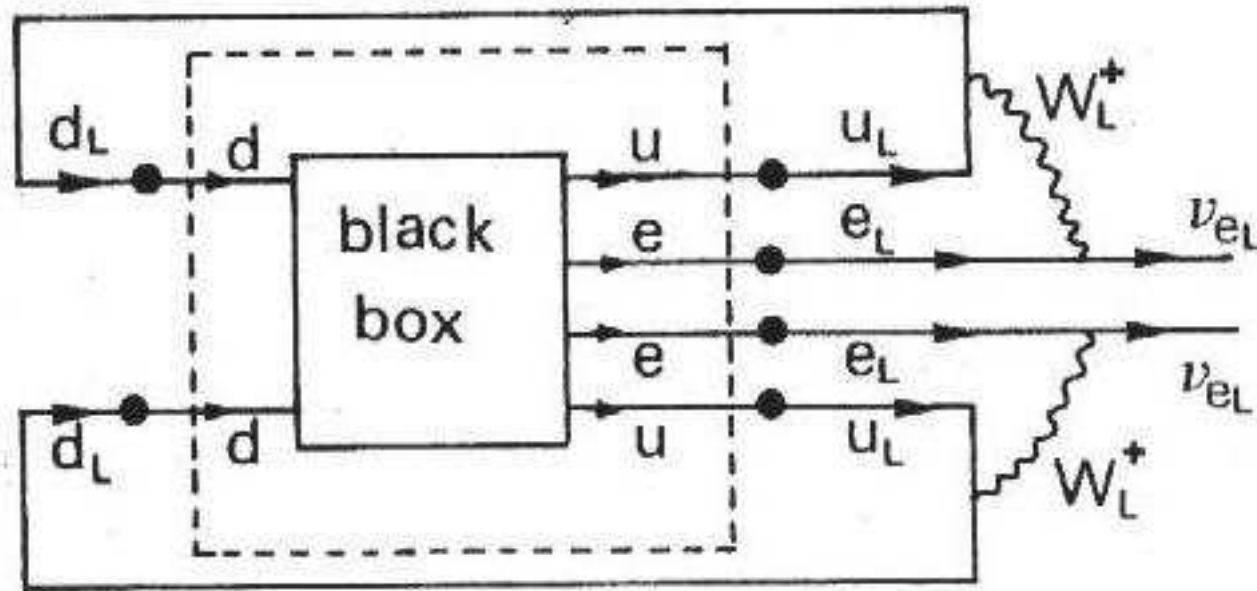

Majorana Mass Term:

$$\mathcal{L}_{eL}^M = -\frac{1}{2} m \left(\overline{\nu_{eL}^c} \nu_{eL} + \overline{\nu_{eL}} \nu_{eL}^c \right) = \frac{1}{2} m \left(\nu_{eL}^T \mathcal{C}^+ \nu_{eL} + \nu_{eL}^+ \mathcal{C} \nu_{eL}^* \right)$$

two conditions: $\left\{ \begin{array}{l} u, d, e \text{ are massive} \\ \text{standard left-handed weak interaction exists} \end{array} \right.$

cancellations with other diagrams are very unlikely (unstable under perturbations)

The Problem of Calculation of Nuclear Matrix Elements

$$(T_{1/2}^{0\nu})^{-1} = G_{0\nu} |\mathcal{M}_{0\nu}|^2 |m_{\beta\beta}|^2$$

$$m_{\beta\beta} = \sum_k U_{ek}^2 m_k$$

Theoretically evaluated $\beta\beta(0\nu)$ half-lives (units of 10^{28} years for $\langle m_\nu \rangle = 10$ meV).

Isotope	[10]	[11]	[12]	[13]	[14]	[15]
^{48}Ca	3.18	8.83	-	-	-	2.5
^{76}Ge	1.7	17.7	14.0	2.33	3.2	3.6
^{82}Se	0.58	2.4	5.6	0.6	0.8	1.5
^{100}Mo	-	-	1.0	1.28	0.3	3.9
^{116}Cd	-	-	-	0.48	0.78	4.7
^{130}Te	0.15	5.8	0.7	0.5	0.9	0.85
^{136}Xe	-	12.1	3.3	2.2	5.3	1.8
^{150}Nd	-	-	-	0.025	0.05	-
^{160}Gd	-	-	-	0.85	-	-

10. W.C. Haxton and G.J. Stephenson Jr., Progr. Part. Nucl. Phys. 12(1984) 409.
11. E. Caurier et al., Nucl. Phys. A 654 (1999) 973.
12. J. Engel et al., Phys. Rev. C 37 (1988) 731.
13. A. Staudt et al., Europhys. Lett 13 (1990) 31.
14. A. Faessler and F. Simkovic, J. Phys. G 24 (1998) 2139.
15. G. Pantis et al., Phys. Rev. C 53 (1996) 695.

[Cremonesi, NPB PS 118 (2003) 287]

traditional estimated range for $|\mathcal{M}_{0\nu}|^2$: about one order of magnitude



about factor of 3 range for $|\mathcal{M}_{0\nu}|$ and $|m_{\beta\beta}|$

$ \mathcal{M}_{0\nu} $	$ m_{\beta\beta} $ [eV]	Method	Reference
1.35	1.24	QRPA with np pairing	Pantis et al. (1999)
1.56	1.07	Large-scale shell model	Caurier et al. (1996)
1.52 – 1.68	1.0 – 1.1	QRPA	Bobyk et al. (2001)
1.87	0.89	Full RQRPA	Simkovic et al. (1997)
2.15	0.78	RQRPA with forbidden	Rodin et al. (2003)
1.68 – 3.36	0.50 – 1.00	RQRPA	Stoica and Klapdor-K. (2001)
2.40	0.70	QRPA with forbidden	Rodin et al. (2003)
1.54 – 3.99	0.42 – 1.09	QRPA	Stoica and Klapdor-K. (2001)
2.07 – 3.30	0.51 – 0.81	Full RQRPA	Stoica and Klapdor-K. (2001)
2.65 – 2.84	0.59 – 0.63	RQRPA	Bobyk et al. (2001)
2.81	0.60	RQRPA with forbidden	Simkovic et al. (1999)
2.98	0.56	QRPA	Suhonen et al. (1992)
3.06	0.55	QRPA	Pantis et al. (1996)
3.10	0.54	Number-projected QRPA	Suhonen et al. (1992)
2.88 – 3.43	0.49 – 0.58	Second QRPA	Stoica and Klapdor-K. (2001)
3.25	0.52	QRPA	Barbero et al. (1999)
3.25	0.51	RQRPA	Faessler and Simkovic (1998)
3.27	0.51	QRPA	Civitarese and Suhonen (2003)
3.63	0.46	RQRPA	Simkovic et al. (1999)
3.78	0.44	QRPA	Muto et al. (1989), Staudt et al. (1990)
3.88	0.43	QRPA	Tomoda (1991)
4.12	0.41	QRPA	Aunola and Suhonen (1998)

[Elliott, Engel, J. Phys. G 30 (2004) R183]

$$(T_{1/2}^{0\nu})^{-1} = G_{0\nu} |\mathcal{M}_{0\nu}|^2 |m_{\beta\beta}|^2$$

$$G_{0\nu} = 0.30 \times 10^{25} \text{ y eV}^{-2}$$

unrealistic
calculations
excluded

$$1.35 \lesssim |\mathcal{M}_{0\nu}| \lesssim 4.12$$

about factor of 3 range
for $|\mathcal{M}_{0\nu}|$ and $|m_{\beta\beta}|$

other estimates

[Bahcall et al, PRD 70 (2004) 033012]

[Fogli et al, hep-ph/0408045]

[Deppisch, Paes, Suhonen, hep-ph/0409306]

Indication of $\beta\beta_{0\nu}$ Decay at Quasi Degenerate Mass Scale

[Klapdor-Kleingrothaus, Dietz, Harney, Krivosheina, Mod. Phys. Lett. A16 (2001) 2409] [Klapdor-Kleingrothaus, Dietz, Krivosheina, Found. Phys. 32 (2002) 1181]

[Klapdor-Kleingrothaus, Dietz, Chkvorez, Krivosheina, NIMA 522 (2004) 371] [Klapdor-Kleingrothaus, Krivosheina, Dietz, Chkvorets, PLB 586 (2004) 198]

$$T_{1/2}^{0\nu\text{bf}} = 1.19 \times 10^{25} \text{ y} \quad T_{1/2}^{0\nu} = (0.69 - 4.18) \times 10^{25} \text{ y} \quad (3\sigma) \quad 4.2\sigma \text{ evidence}$$

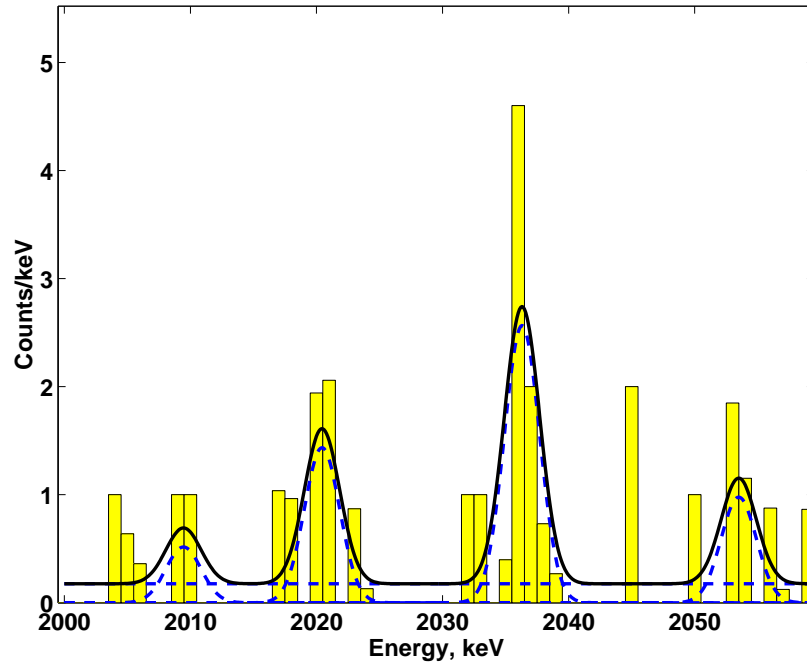

pulse-shape selected spectrum

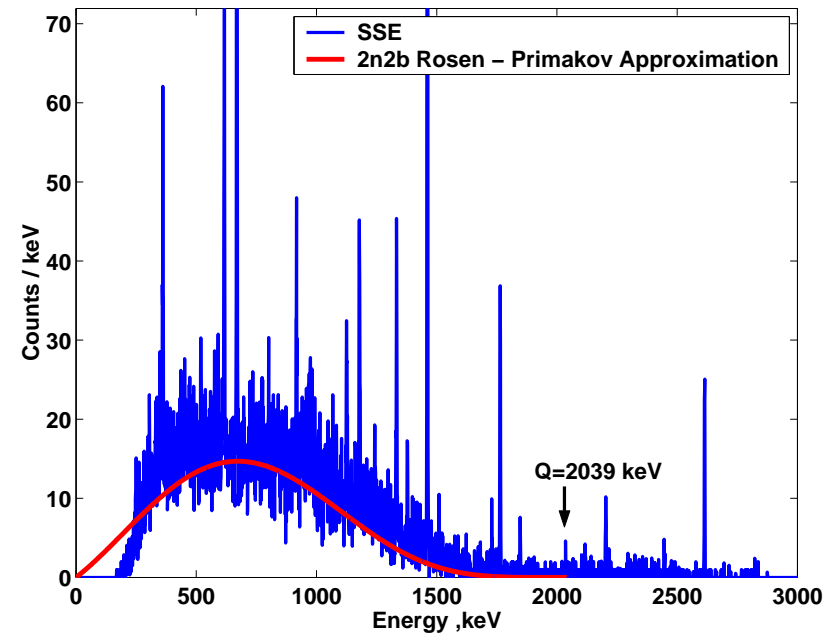

3.8 σ evidence

[PLB 586 (2004) 198]

the indication must be checked by other experiments

$$1.35 \lesssim |\mathcal{M}_{0\nu}| \lesssim 4.12 \quad \implies \quad 0.22 \text{ eV} \lesssim |m_{\beta\beta}| \lesssim 1.6 \text{ eV}$$

if confirmed very exciting (Majorana ν and large mass scale)

Best limits for $\beta\beta_{0\nu}$ Decay

Heidelberg-Moscow

^{76}Ge

[EPJA 12 (2001) 147]

$$T_{1/2}^{0\nu} > 1.9 \times 10^{25} \text{ y} \quad (90\% \text{ C.L.})$$

\Rightarrow

$$|m_{\beta\beta}| \lesssim 0.32 - 1.0 \text{ eV} \quad (90\% \text{ C.L.})$$

IGEX

^{76}Ge

[PRD 65 (2002) 092007]

$$T_{1/2}^{0\nu} > 1.57 \times 10^{25} \text{ y} \quad (90\% \text{ C.L.})$$

\Rightarrow

$$|m_{\beta\beta}| \lesssim 0.35 - 1.1 \text{ eV} \quad (90\% \text{ C.L.})$$

FUTURE EXPERIMENTS

NEMO3, CUORICINO, COBRA, XMASS, CAMEO, CANDLES $|m_{\beta\beta}| \sim \text{few } 10^{-1} \text{ eV}$

EXO, MOON, Super-NEMO, CUORE, Majorana, GEM, GERDA $|m_{\beta\beta}| \sim \text{few } 10^{-2} \text{ eV}$

see [Zdesenko, RMP 74 (2002) 663], [Elliott,Vogel, Ann. Rev. Nucl. Part. Sci. 52 (2002) 115], [Elliott, Engel, J. Phys. G 30 (2004) R183]

Neutrino Oscillations Bounds for $\beta\beta_{0\nu}$ Decay

$$m_{\beta\beta} = \sum_k U_{ek}^2 m_k$$

complex $U_{ek} \Rightarrow$ possible cancellations

$$\begin{aligned} m_{\beta\beta} &= |U_{e1}|^2 m_1 + |U_{e2}|^2 e^{2i\lambda_{21}} m_2 + |U_{e3}|^2 e^{2i(\lambda_{31}-\delta)} m_3 \\ &= |U_{e1}|^2 m_1 + |U_{e2}|^2 e^{i\alpha_{21}} m_2 + |U_{e3}|^2 e^{i\alpha_{31}} m_3 \end{aligned}$$

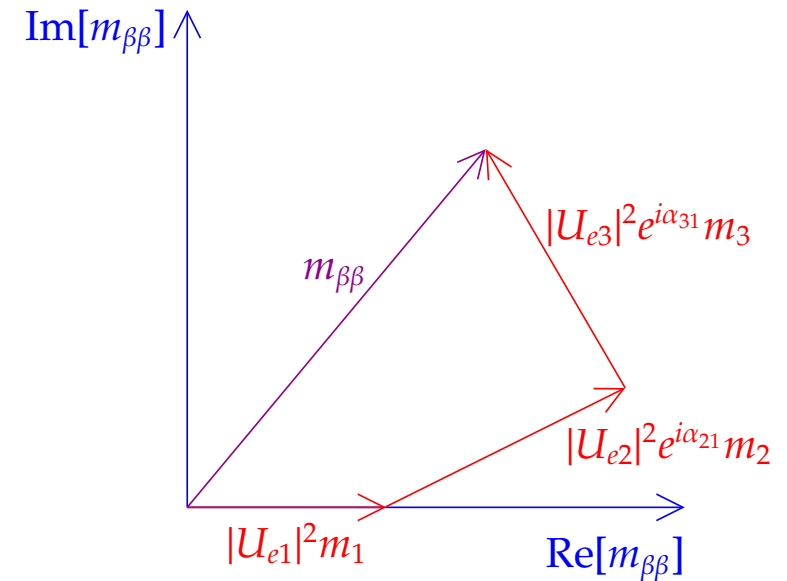

conserved CP $\Rightarrow \delta = 0 \quad \lambda_{kj} = \frac{\alpha_{kj}}{2} = 0, \frac{\pi}{2} \Rightarrow e^{2i\lambda_{kj}} = e^{i\alpha_{kj}} = \pm 1$

$\delta \neq 0 \Rightarrow$ calling “Majorana phases” λ_{kj} or $\alpha_{kj}/2$ is a convention

$$\begin{pmatrix} c_{12}c_{13} & s_{12}c_{13} & s_{13}e^{-i\delta} \\ \dots & \dots & s_{23}c_{13} \\ \dots & \dots & c_{23}c_{13} \end{pmatrix} \begin{pmatrix} 1 & 0 & 0 \\ 0 & e^{i\lambda_{21}} & 0 \\ 0 & 0 & e^{i\lambda_{31}} \end{pmatrix} = \begin{pmatrix} c_{12}c_{13} & s_{12}c_{13} & s_{13} \\ \dots & \dots & s_{23}c_{13}e^{i\delta} \\ \dots & \dots & c_{23}c_{13}e^{i\delta} \end{pmatrix} \begin{pmatrix} 1 & 0 & 0 \\ 0 & e^{i\alpha_{21}/2} & 0 \\ 0 & 0 & e^{i\alpha_{31}/2} \end{pmatrix}$$

Normal Hierarchy $m_1 \ll m_2 \ll m_3$

$$|m_{\beta\beta}| = \left| \sum_k U_{ek}^2 m_k \right| \simeq |U_{e2}^2 m_2 + U_{e3}^2 m_3| = \left| |U_{e2}|^2 m_2 + |U_{e3}|^2 e^{i(\alpha_{31} - \alpha_{21})} m_3 \right| \leq |U_{e2}|^2 m_2 + |U_{e3}|^2 m_3$$

$$m_2 \simeq \sqrt{\Delta m_{21}^2} \simeq \sqrt{\Delta m_{\text{SUN}}^2} \quad m_3 \simeq \sqrt{\Delta m_{31}^2} \simeq \sqrt{\Delta m_{\text{ATM}}^2}$$

$$1.8 \times 10^{-3} \lesssim |U_{e2}|^2 m_2 \lesssim 3.6 \times 10^{-3} \quad |U_{e3}|^2 m_3 \lesssim 2.9 \times 10^{-3}$$

ν_2 contribution $|U_{e2}|^2 m_2$ may be dominant! (no cancellation \implies lower limit for $|m_{\beta\beta}|$)

[Giunti, PRD 61 (2000) 036002]

overlap of allowed ranges for $|U_{e2}|^2 m_2$ and $|U_{e3}|^2 m_3 \implies$ strong cancellation is possible

in any case: $|m_{\beta\beta}| \lesssim 6 \times 10^{-3} \text{ eV}$

[Vissani, JHEP 06 (1999) 022]

[Bilenky et al, PLB 465 (1999) 193]

the difference $\alpha_{31} - \alpha_{21}$ of the two Majorana phases is potentially measurable

$$|m_{\beta\beta}|^2 \simeq |U_{e2}|^4 \Delta m_{\text{SUN}}^2 + |U_{e3}|^4 \Delta m_{\text{ATM}}^2 + 2 |U_{e2}|^2 |U_{e3}|^2 \sqrt{\Delta m_{\text{SUN}}^2} \sqrt{\Delta m_{\text{ATM}}^2} \cos(\alpha_{31} - \alpha_{21})$$

[Bilenky, Pascoli, Petcov, PRD 64 (2001) 053010]

CP Conservation: Normal Scheme

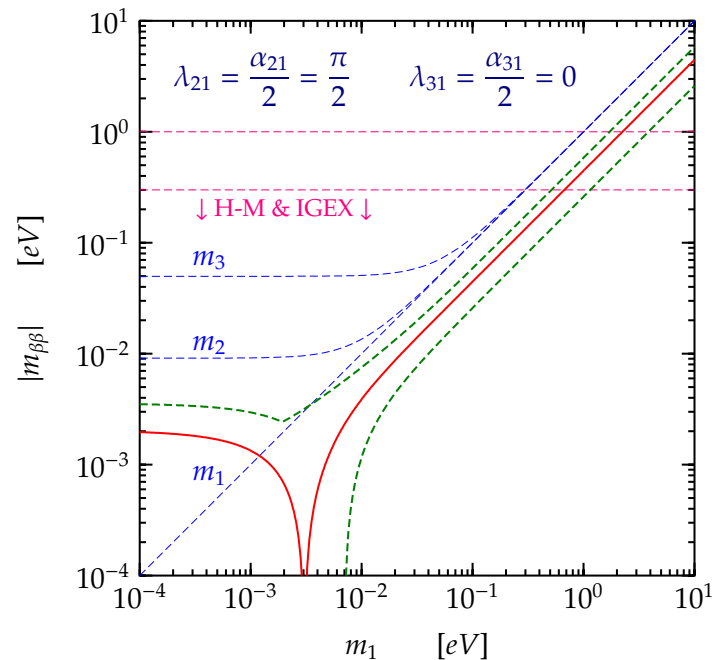
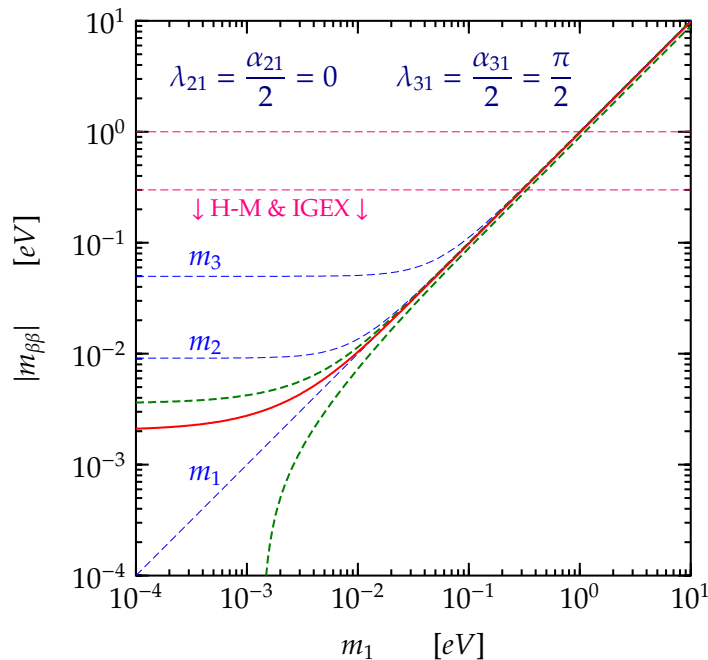
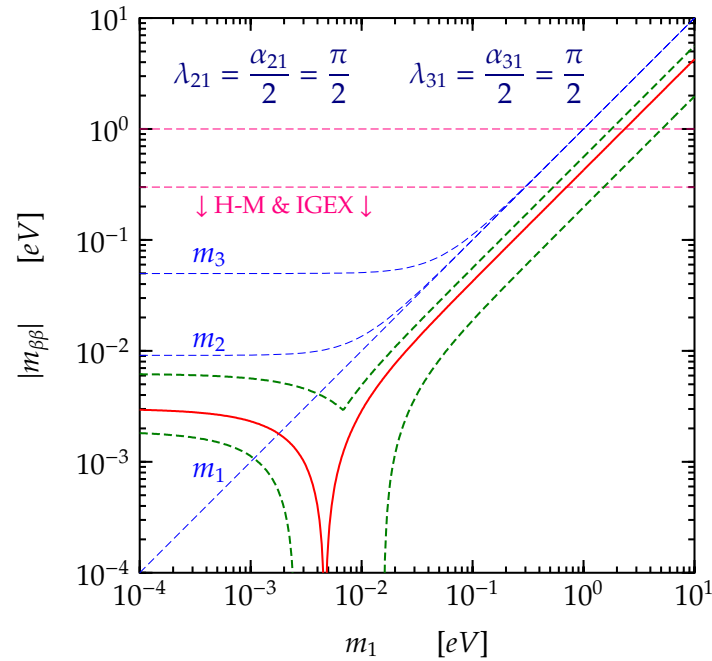
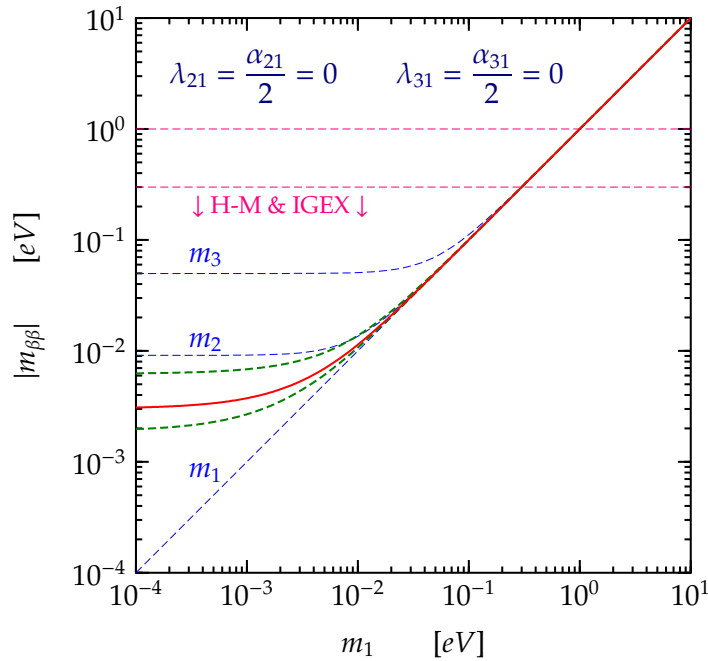

$$\begin{aligned}
 m_{\beta\beta} &\simeq |U_{e1}|^2 m_1 \\
 &+ |U_{e2}|^2 e^{i\alpha_{21}} \sqrt{m_1^2 + \Delta m_{\text{SUN}}^2} \\
 &+ |U_{e3}|^2 e^{i\alpha_{31}} \sqrt{m_1^2 + \Delta m_{\text{ATM}}^2}
 \end{aligned}$$

$$\Delta m_{\text{SUN}}^2 \simeq (7.4 - 9.3) \times 10^{-5} \text{eV}^2$$

$$\Delta m_{\text{ATM}}^2 \simeq (1.8 - 3.2) \times 10^{-3} \text{eV}^2$$

$$|U_{e1}|^2 \simeq 0.59 - 0.77$$

$$|U_{e2}|^2 \simeq 0.21 - 0.37$$

$$|U_{e3}|^2 \simeq 0.00 - 0.05$$

Inverted Hierarchy $m_1 \simeq m_2 \gg m_3$

$$\begin{aligned} |m_{\beta\beta}| &= \left| \sum_k U_{ek}^2 m_k \right| \simeq |U_{e1}^2 m_1 + U_{e2}^2 m_2| \\ &\simeq |U_{e1}^2 + U_{e2}^2| \sqrt{\Delta m_{\text{ATM}}^2} \\ &= \left| |U_{e1}|^2 + |U_{e2}|^2 e^{i\alpha_{21}} \right| \sqrt{\Delta m_{\text{ATM}}^2} \end{aligned}$$

$$0.59 \lesssim |U_{e1}|^2 \lesssim 0.77 \quad 0.21 \lesssim |U_{e2}|^2 \lesssim 0.37$$

no overlap of allowed ranges for $|U_{e1}|^2$ and $|U_{e2}|^2 \implies$ complete cancellation is not possible!

$$|m_{\beta\beta}| \sim \sqrt{\Delta m_{\text{ATM}}^2}$$

the Majorana phase α_{21} is potentially measurable

[Bilenky et al, PRD 54 (1996) 4432]

$$\frac{|m_{\beta\beta}|^2}{\Delta m_{\text{ATM}}^2} \simeq |U_{e1}|^4 + |U_{e2}|^4 + 2|U_{e1}|^2 |U_{e2}|^2 \cos \alpha_{21}$$

CP Conservation: Inverted Scheme

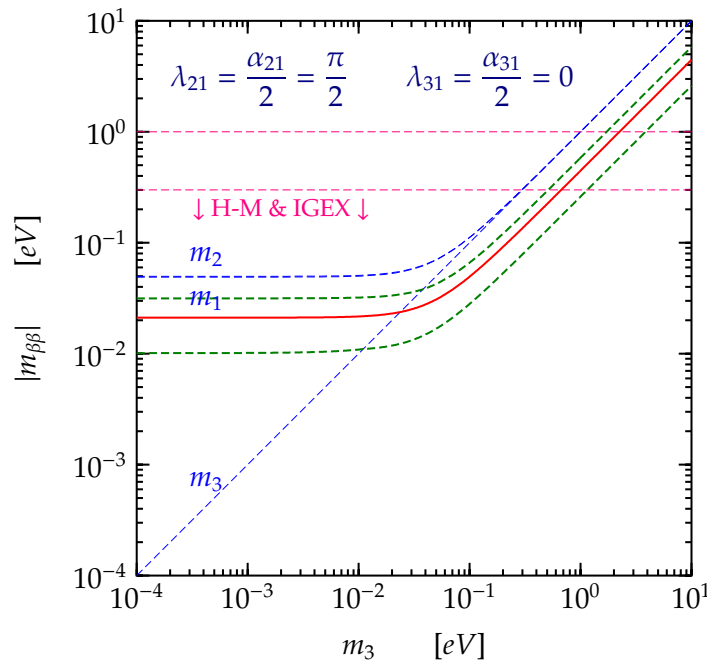
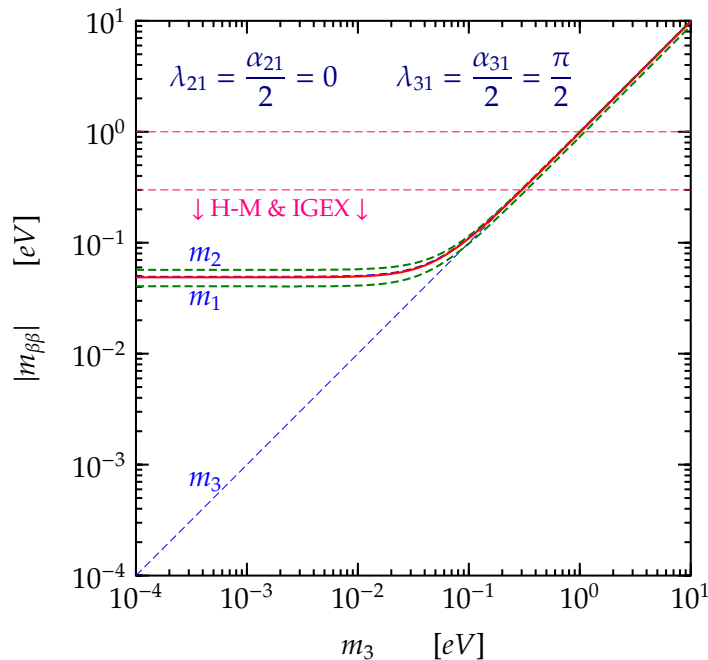
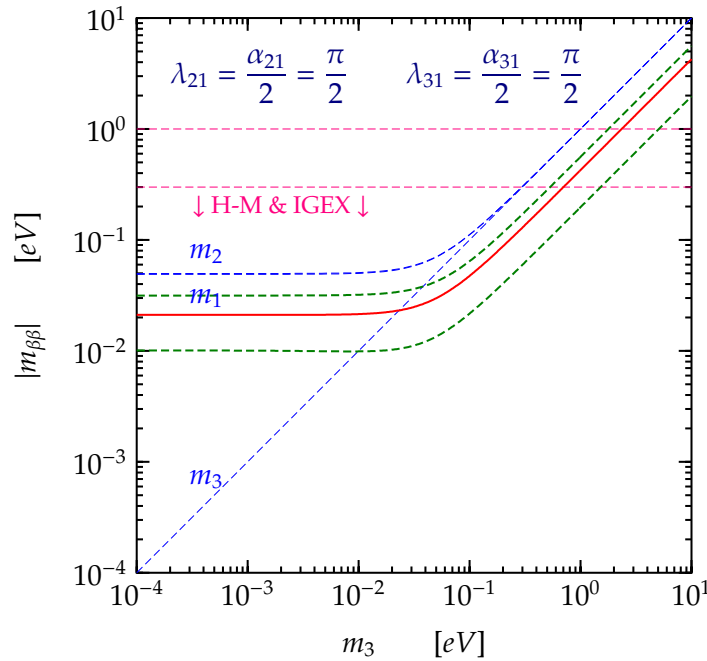
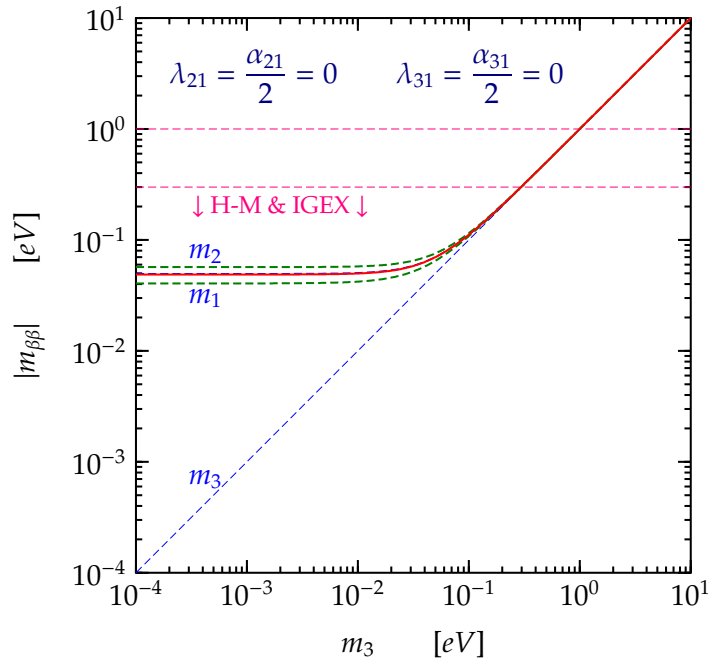

$$m_{\beta\beta} \simeq \left(|U_{e1}|^2 + |U_{e2}|^2 e^{i\alpha_{21}} \right) \times \sqrt{m_3^2 + \Delta m_{\text{ATM}}^2} + |U_{e3}|^2 e^{i\alpha_{31}} m_3$$

$$\Delta m_{\text{ATM}}^2 \simeq (1.8 - 3.2) \times 10^{-3} \text{eV}^2$$

$$|U_{e1}|^2 \simeq 0.59 - 0.77$$

$$|U_{e2}|^2 \simeq 0.21 - 0.37$$

$$|U_{e3}|^2 \simeq 0.00 - 0.05$$

General Neutrino Oscillations Bounds for $\beta\beta_{0\nu}$ Decay

[Vissani, JHEP 06 (1999) 022] [Pascoli et al, PLB 549 (2002) 177] [Czakon et al, PRD65 (2002) 053008] [Elliott, Vogel, ARNPS 52 (2002) 115]
 [Joaquim, PRD68 (2003) 033019] [Giunti, Laveder, hep-ph/0310238] [Feruglio et al, NPB659 (2003) 359] [Pascoli, Petcov, PLB 580 (2004) 280]
 [Bilenky et al, PRD70 (2004) 033003] [Bahcall et al, PRD 70 (2004) 033012] [Petcov, NJP 6 (2004) 109]

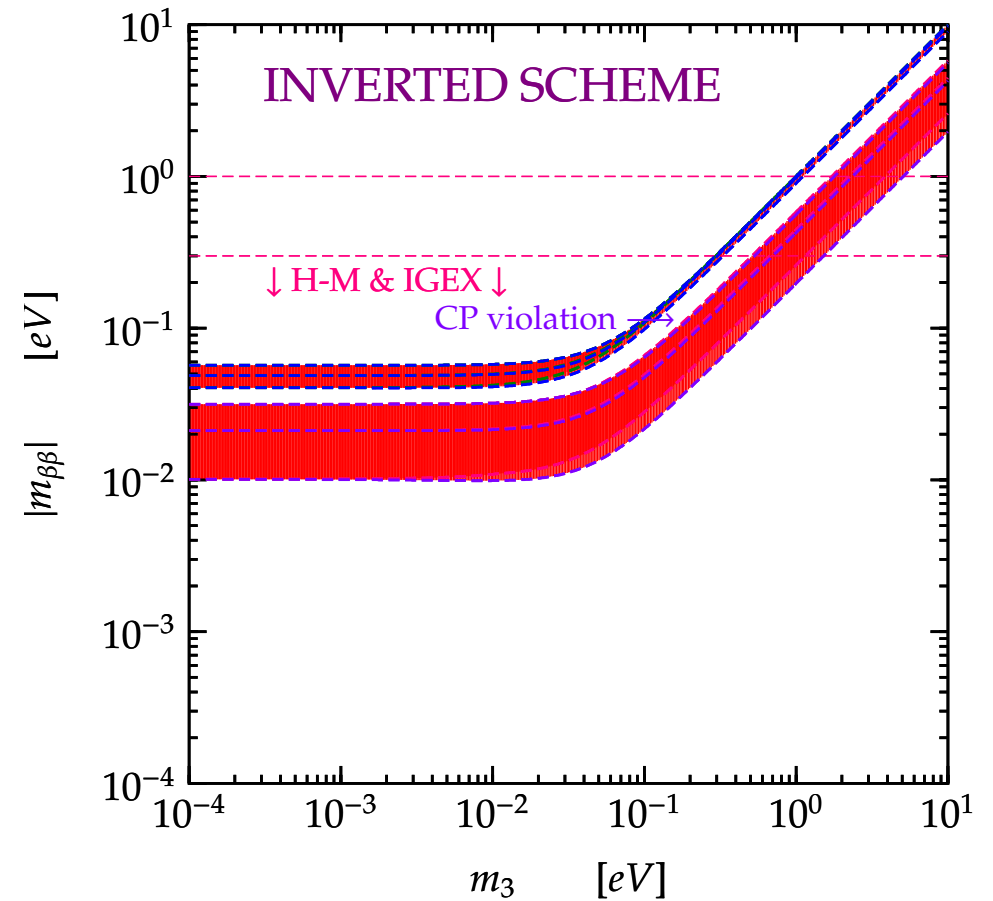
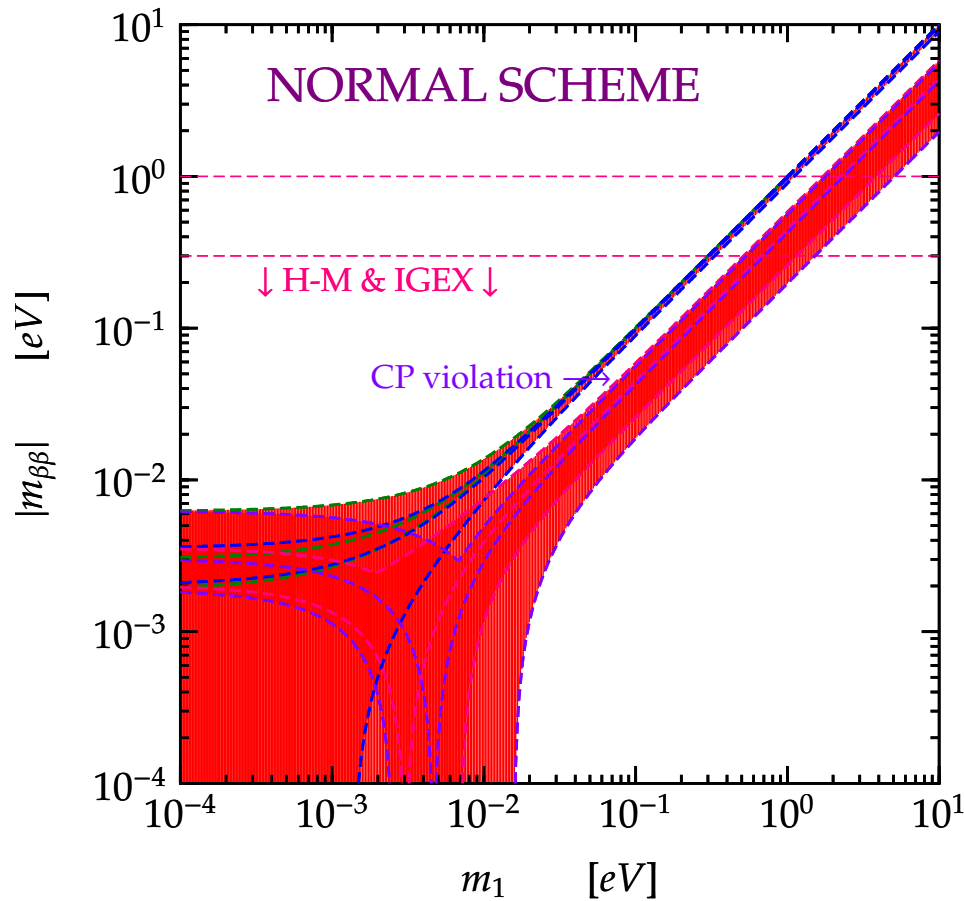

Quasi Degenerate: $m_1 \simeq m_2 \simeq m_3 \simeq m_\nu \implies |m_{\beta\beta}| \simeq \left| |U_{e1}|^2 + |U_{e2}|^2 e^{i\alpha_{21}} + |U_{e3}|^2 e^{i\alpha_{31}} \right| m_\nu$

FUTURE: IF $|m_{\beta\beta}| \lesssim 10^{-2}$ eV \implies NORMAL HIERARCHY

Indication of $\beta\beta_{0\nu}$ Decay at Quasi Degenerate Mass Scale

$$0.22 \text{ eV} \lesssim |m_{\beta\beta}| \lesssim 1.6 \text{ eV} \quad (3\sigma \text{ range})$$

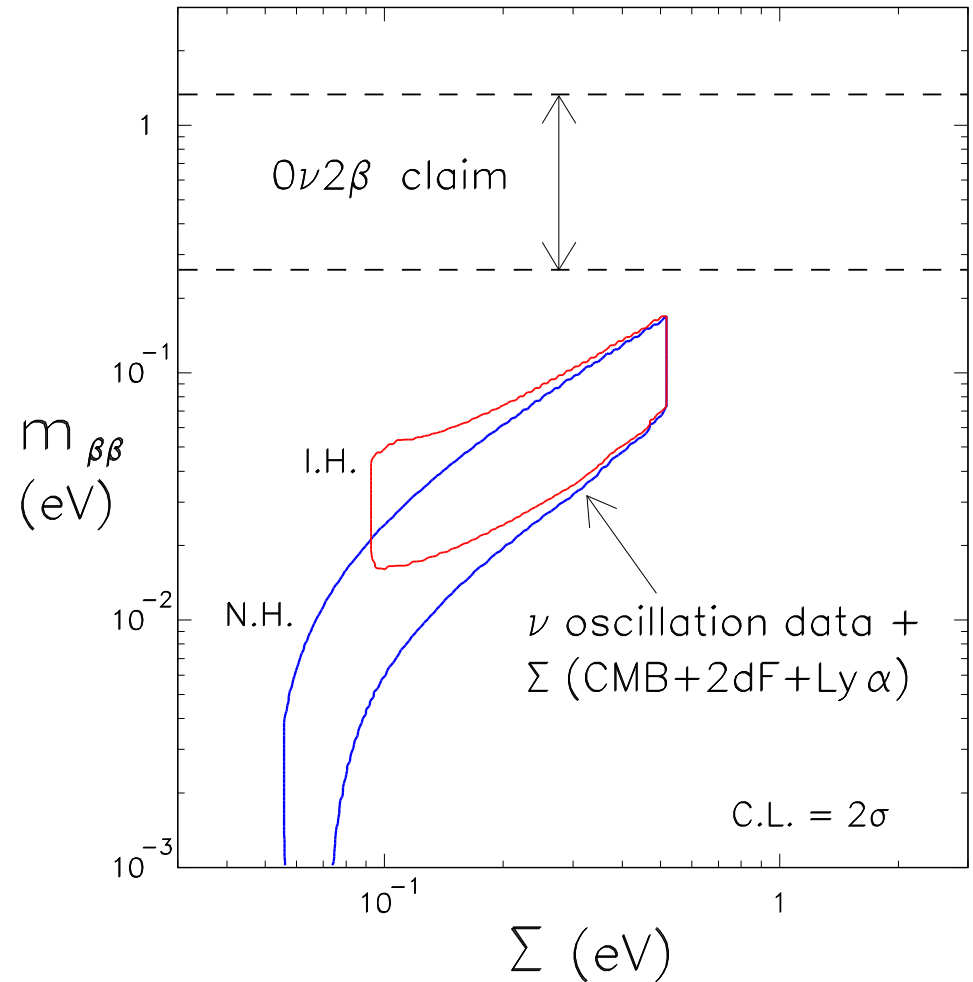
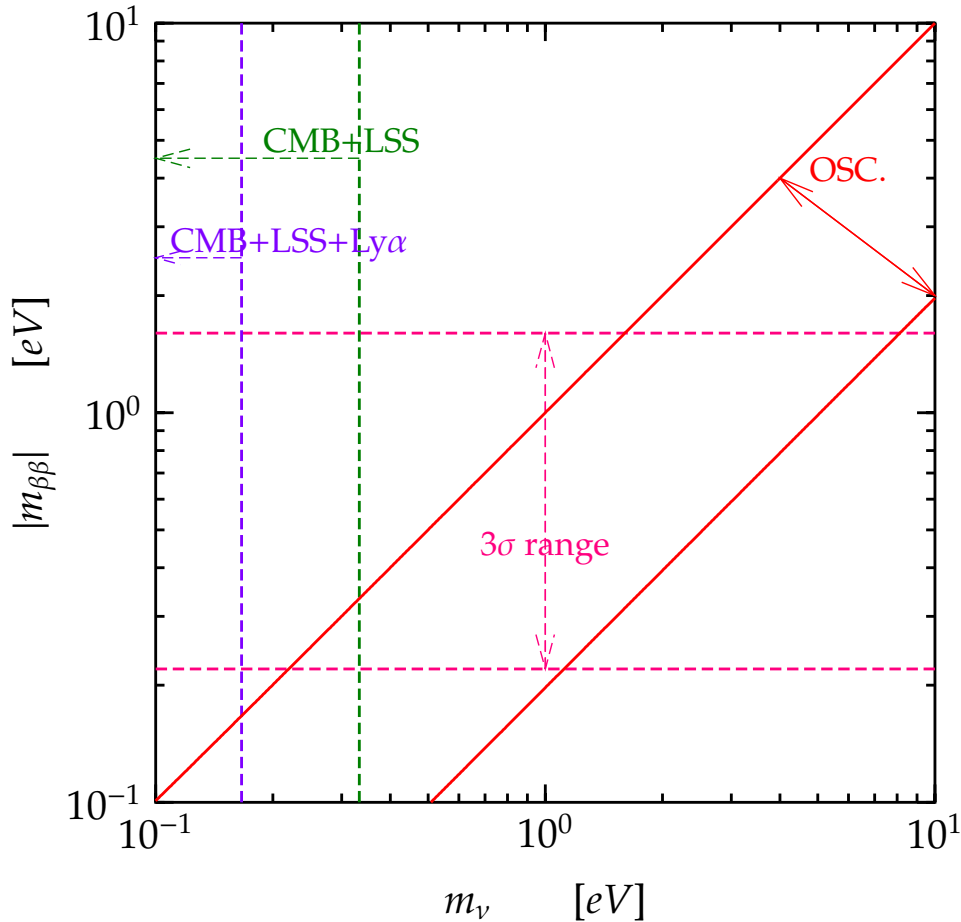

[Fogli, Lisi, Marrone, Melchiorri, Palazzo, Serra, Silk, hep-ph/0408045]

tension among oscillation data, CMB+LSS+Ly α and $\beta\beta_{0\nu}$ signal

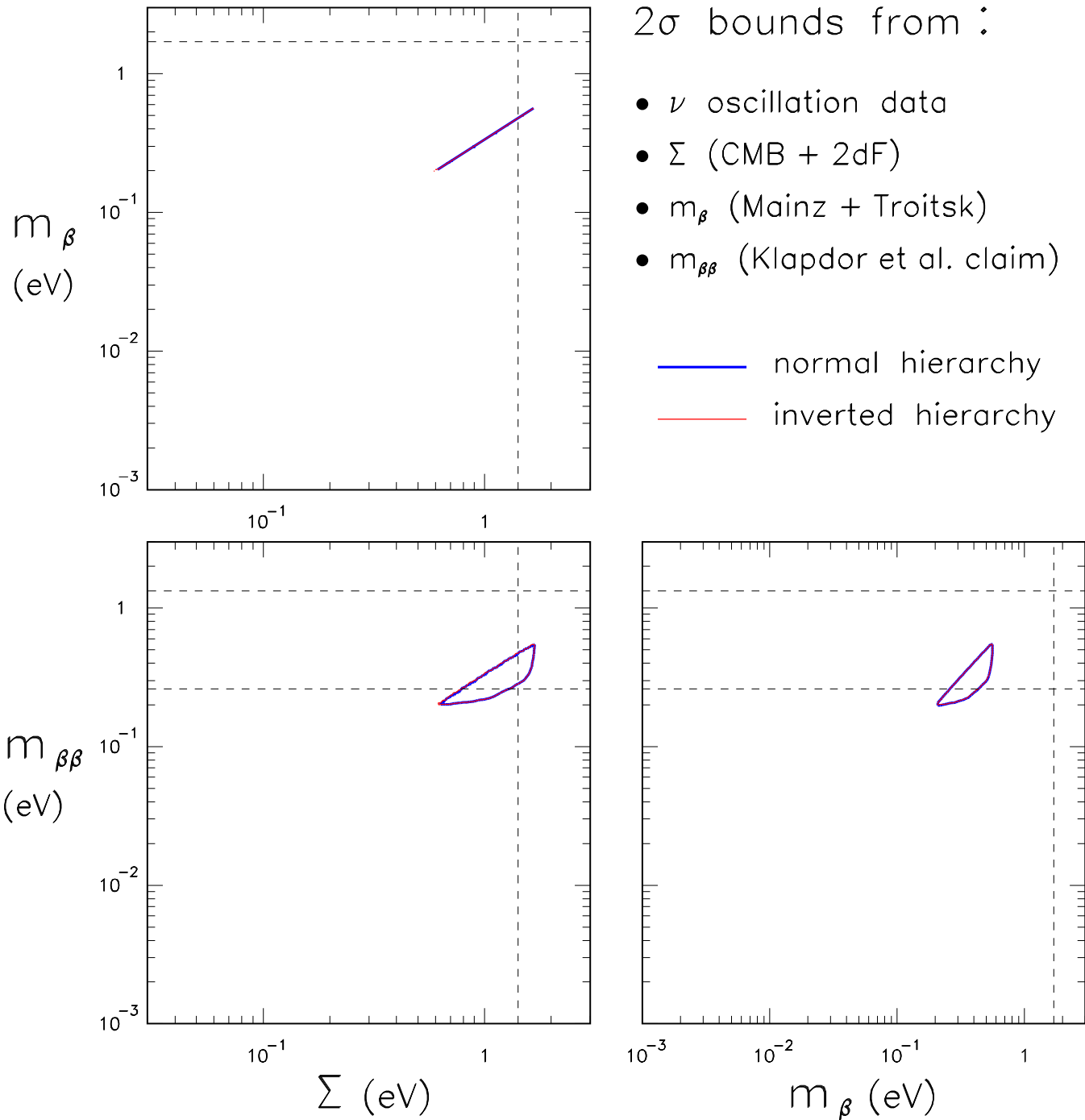

[Fogli, Lisi, Marrone, Melchiorri, Palazzo, Serra, Silk, hep-ph/0408045]

Summary

$\nu_e \rightarrow \nu_\mu, \nu_\tau$ with $\Delta m_{\text{SUN}}^2 \simeq 8.3 \times 10^{-5} \text{ eV}^2$ (solar ν , KamLAND)

$\nu_\mu \rightarrow \nu_\tau$ with $\Delta m_{\text{ATM}}^2 \simeq 2.4 \times 10^{-3} \text{ eV}^2$ (atmospheric ν , K2K)



Bilarge 3ν -Mixing with $|U_{e3}|^2 \ll 1$

β Decay, Cosmology, $\beta\beta_{0\nu}$ Decay $\Rightarrow m_\nu \lesssim 1 \text{ eV}$

FUTURE

Theory: Why $m_\nu \ll m_e$? Why only $|U_{e3}|^2 \ll 1$?

Exp.: Measure $|U_{e3}| > 0 \Rightarrow$ normal or inverted scheme and CP violation in ν osc.

Check $\beta\beta_{0\nu}$ signal at Quasi Degenerate mass scale

Improve bounds from β Decay, Cosmology, $\beta\beta_{0\nu}$ Decay

Conclusions

Neutrino Physics is a very active and interesting field of research

next years will hopefully bring new interesting results

Open Fundamental Questions

Absolute Scale of Neutrino Masses?

Nature of Neutrinos (Dirac or Majorana)?

Are There Sterile Neutrinos?

Short-Baseline $\bar{\nu}_\mu \rightarrow \bar{\nu}_e$ (LSND)? \Leftarrow MiniBooNE

Electromagnetic Properties of Neutrinos?

Neutrino Unbound

<http://www.nu.to.infn.it>

Carlo Giunti & Marco Laveder